

Quest® Secure Copy® 7.7

## User Guide



© 2025 Quest Software Inc.

## ALL RIGHTS RESERVED.

This guide contains proprietary information protected by copyright. The software described in this guide is furnished under a software license or nondisclosure agreement. This software may be used or copied only in accordance with the terms of the applicable agreement. No part of this guide may be reproduced or transmitted in any form or by any means, electronic or mechanical, including photocopying and recording for any purpose other than the purchaser's personal use without the written permission of Quest Software Inc.

The information in this document is provided in connection with Quest Software products. No license, express or implied, by estoppel or otherwise, to any intellectual property right is granted by this document or in connection with the sale of Quest Software products. EXCEPT AS SET FORTH IN THE TERMS AND CONDITIONS AS SPECIFIED IN THE LICENSE AGREEMENT FOR THIS PRODUCT, QUEST SOFTWARE ASSUMES NO LIABILITY WHATSOEVER AND DISCLAIMS ANY EXPRESS, IMPLIED OR STATUTORY WARRANTY RELATING TO ITS PRODUCTS INCLUDING, BUT NOT LIMITED TO, THE IMPLIED WARRANTY OF MERCHANTABILITY, FITNESS FOR A PARTICULAR PURPOSE, OR NON-INFRINGEMENT. IN NO EVENT SHALL QUEST SOFTWARE BE LIABLE FOR ANY DIRECT, INDIRECT, CONSEQUENTIAL, PUNITIVE, SPECIAL OR INCIDENTAL DAMAGES (INCLUDING, WITHOUT LIMITATION, DAMAGES FOR LOSS OF PROFITS, BUSINESS INTERRUPTION OR LOSS OF INFORMATION) ARISING OUT OF THE USE OR INABILITY TO USE THIS DOCUMENT, EVEN IF QUEST SOFTWARE HAS BEEN ADVISED OF THE POSSIBILITY OF SUCH DAMAGES. Quest Software makes no representations or warranties with respect to the accuracy or completeness of the contents of this document and reserves the right to make changes to specifications and product descriptions at any time without notice. Quest Software does not make any commitment to update the information contained in this document.

If you have any questions regarding your potential use of this material, contact:

Quest Software Inc.

20 Enterprise, Suite 100,

Aliso Viejo, CA 92656

Refer to our Web site (<https://www.quest.com>) for regional and international office information.

## Patents

Quest Software is proud of our advanced technology. Patents and pending patents may apply to this product. For the most current information about applicable patents for this product, please visit our website at <https://www.quest.com/legal>.

## Trademarks

Quest, Secure Copy, the Quest logo, and Join the Innovation are trademarks and registered trademarks of Quest Software Inc. For a complete list of Quest marks, visit <https://www.quest.com/legal/trademark-information.aspx>. All other trademarks and registered trademarks are property of their respective owners.

## Legend



**CAUTION:** A CAUTION icon indicates potential damage to hardware or loss of data if instructions are not followed.



**IMPORTANT, NOTE, TIP, MOBILE,** or **VIDEO:** An information icon indicates supporting information.

Secure Copy User Guide  
Updated - August 2025  
Software Version - 7.7

# Contents

<b>Using Secure Copy .....</b>	<b>6</b>
About Secure Copy .....	6
Starting Secure Copy .....	6
Examining the main window .....	6
Setting default performance settings .....	7
Setting SMTP settings.....	8
Setting general preferences .....	9
Setting logging settings .....	9
Creating a basic job .....	10
Changing basic copy job settings .....	10
Selecting actions .....	11
<b>Setting copy options.....</b>	<b>12</b>
About copy options.....	12
Setting copy locations .....	12
Setting synchronization .....	13
Synchronizing single source path to single target path .....	16
Synchronizing multiple source paths to single target path .....	19
Applying filters .....	25
Filtering files.....	25
Filtering folders .....	26
Copying folder structures without files .....	26
Setting performance options .....	27
Verifying file copy .....	27
Enabling logging .....	27
Maximizing copy performance.....	28
Retrying on locked files or network errors .....	29
Closing the Jobs Progress window .....	29
Migrating local groups and users .....	30
Using map files to migrate local groups and users.....	31
Migrating file shares .....	32
Setting other file options.....	32
Using map files to copy files and folders .....	33
Copying encrypted files .....	33
Copying off-line/stub files .....	34
Copying recently modified files.....	34
Using compression .....	34
Copying ACL information.....	35
Running pre and post migration tasks .....	35

Sending email notifications .....	36
<b>Running copy jobs.....</b>	<b>38</b>
Starting a copy job .....	38
Restarting a copy job .....	39
Importing a job .....	39
Restoring job settings.....	40
Scheduling jobs.....	40
Managing scheduled jobs .....	41
Viewing job status .....	41
Viewing logs and reports.....	41
Viewing copy job statistics .....	41
Viewing log file contents.....	42
Filtering log file contents.....	42
Exporting logs .....	42
Deleting logs .....	43
Running reports.....	43
Analyzing file systems statistics.....	44
<b>Using the command line.....</b>	<b>45</b>
Using SecureCopyCmd.exe.....	45
Using Analyzer from the command line .....	46
<b>Managing licenses .....</b>	<b>47</b>
Viewing licenses.....	47
Viewing licensed servers.....	47
Applying a new license file .....	48
Checking for product updates .....	48
<b>Running Update Utilities .....</b>	<b>49</b>
Home Path Updater .....	49
Profile Path Updater.....	51
Shortcut Updater .....	52
Link Updater .....	53
Creating a link map .ini file .....	55
Running Link Updater from the command line.....	55
Using a .ini file from the command line .....	57
Link Updater for Access.....	57
Registry Updater .....	58
Creating the drive mapping .ini file .....	58
Running the Registry Updater .....	59
Running Registry Updater from the command line .....	59
Using the Registry Updater in a logon script.....	59
<b>Troubleshooting.....</b>	<b>60</b>
Logging events for Technical Support .....	60
Removing Secure Copy .....	60
<b>PowerShell cmdlets .....</b>	<b>62</b>

What are cmdlets? .....	62
Using the PowerShell cmdlets .....	63
Managing copy jobs .....	63
Starting a copy job .....	63
Removing a copy job .....	64
Running the File System Statistics Analyzer .....	64
<b>About us.....</b>	<b>66</b>

---

# Using Secure Copy

- [About Secure Copy](#)
- [Starting Secure Copy](#)
- [Examining the main window](#)
- [Setting default performance settings](#)
- [Setting SMTP settings](#)
- [Setting general preferences](#)
- [Setting logging settings](#)

## About Secure Copy

Quest® Secure Copy® is a comprehensive solution for data duplication, local group and user migration, share migration, and NTFS permissions configuration. Secure Copy permits seamless migration, allowing an administrator to copy files and directories on NTFS partitions while keeping the security intact, creating shares, and migrating local groups. All of this functionality is available in an easy to use interface, which keeps you updated on copy progress, as well as any errors that may occur.

Secure Copy also includes functionality such as differential copying, full command line support, and scheduling jobs to run after hours. Secure Copy supports Windows® 8.1/10, Windows Server 2008, Windows Server 2008 R2, Windows Server 2012, Windows Server 2012 R2, Windows Server 2016, and Windows Server 2019 environments and is compatible with the Microsoft® Cluster Service.

## Starting Secure Copy

### *To start Secure Copy*

- Click **Start**, point to **Programs | Quest | Secure Copy 7**, and choose **Secure Copy 7**.

## Examining the main window

When you first open Secure Copy®, the Job Summary page for the Default job displays. The display is divided into two panes.

- In the pane on the left, you can view a list of the copy jobs you create. Beneath each copy job is a list of the options that you can set. At the bottom of the Jobs pane are the module buttons where you can choose to view the job status, run update utilities, view logs, or run reports.
- In the pane on the right, you view the job summary or the selected option page.

You can create and run a copy job quickly from the Job Summary page, or you can create a more complex copy job by using the copy options that are listed beneath each copy job in the Jobs pane. See [creating a basic job](#) and [Setting copy options](#).

# Setting default performance settings

**i** **NOTE:** These settings apply to all new copy jobs. For each individual copy job, you can override these settings on the Performance page. See [Maximizing performance options](#).

**IMPORTANT:** In most cases, the default values are optimal. Changing these values incorrectly can lead to performance degradation.

## To set performance options

- 1 Select **Tools | New Job Options**.
- 2 On the **Performance Settings** page, set the desired options.

Table 1. Performance settings

Option	Description
Thread count (2-250)	<p>Select the number of copy threads for an individual copy job. The number of threads is equivalent to the number of copy jobs that can be performed simultaneously. The minimum is 2 and the maximum is 250.</p> <ul style="list-style-type: none"><li>• When moving a large number of small files, you can increase the number of threads towards the maximum number of 250 threads. With more threads per job, large numbers of files can be moved in the shortest period of time.</li><li>• When moving larger files, using fewer threads is more effective because the threads are able to focus on moving a few large files, switching control between few threads in a fluid process rather than passing control to multiple threads, which would slow down the copy process.</li></ul>
Batch count (25-1000)	<p>Select the maximum number of files in an individual copy job thread. Batch Count is a limiter based on the number of files a thread can process at a time. When a job is being processed, a single thread copies either the maximum number of files in the batch count or the maximum batch size, whichever is reached first. The minimum number of files is 25 and the maximum is 1000.</p> <ul style="list-style-type: none"><li>• When processing a large number of small files, it is preferable to set the batch count to the highest level for efficiency.</li><li>• When processing large files, the batch count can be set anywhere because the batch size limitation will be met before the batch count limit is met.</li></ul>

Option	Description
Batch size (1-100 MB)	<p>Select the maximum number of bytes in an individual copy job thread. Batch Size is a limiter based on the size of the files a thread can process at a time. When a job is being processed, a single thread copies either the maximum size of files or the maximum number of files, whichever is reached first. The minimum is 1 MB and the maximum is 100 MB.</p> <ul style="list-style-type: none"> <li>When processing a large number of small files, it is preferable to set the batch size to the highest level for efficiency.</li> <li>When processing large files, the batch size can be set anywhere because the batch size limitation will be met prior to meeting the limit of the batch count.</li> </ul>
Inter-Packet Gap (0-1000 ms)	<p>By default, the Inter-Packet Gap is set to zero. The Inter-Packet Gap (IPG), which is also referred to as an Interframe Gap (IFG), slows down the copy process, which reduces the bandwidth usage over the network. As a file is copied, it is copied 64 kilobytes at a time. The Inter-Packet Gap is a time span in milliseconds (ms) to wait before sending the next 64 kilobytes.</p> <p><b>NOTE:</b> Due to factors, such as the volume of other traffic on the network, you may need to experiment with the time span to achieve a desired bandwidth.</p>
Retry attempts on locked files	<p>Choose the number of times to attempt a retry on locked files. The minimum number of attempts is 0 and the maximum is 100. The default is 5 retry attempts.</p>
Minutes between retries on locked files	<p>Choose the number of minutes to wait between each retry on locked files. The default is 30 minutes.</p>
Retry attempts on network errors	<p>Choose the number of times to attempt a retry on network errors. The minimum number of attempts is 1 and the maximum is 100. The default is 3 retry attempts.</p>
Seconds between retries on network errors	<p>Choose the number of minutes to wait between each retry on network errors. The minimum number of seconds is 1 and the maximum is 3,600. The default is 10 seconds.</p>
Close job progress window automatically when no errors occur	<p>Select to close the job progress window when no errors occur. When running a job, you can clear the check box to keep the job progress window open.</p>

## Setting SMTP settings

**i** **NOTE:** These settings apply to all newly created copy jobs. For an individual copy job, you can override these settings on the **Email** page. See [Sending email notifications](#).

### To set SMTP settings

- 1 Select **Tools | New Job Options**.
- 2 Open the **SMTP Settings** tab.
- 3 Enter the SMTP server host name and port.
- 4 Select the encryption method.

**i** **NOTE:** If you are using the Gmail™ webmail service, select the **STARTLS** encryption method to enable the SMTP connection to use SSL/TLS.

- 5 Enter a user name and password.

- 6 Enter a valid email address to appear in the From field on the email.
- 7 To send a test email, click **Send Test Email**.
- 8 Click **OK**.

## Setting general preferences

On the **General Settings** page, you can choose to restore Secure Copy to the state it was left in when you last closed it, to show or hide tool tips, to remove the animation from the Secure Copy splash screen, and to show or hide a context menu in Windows® Explorer.

### To set general preferences

- 1 Select **Tools | Preferences**.
- 2 On the **General Settings** page, set general options.

Table 2. General settings

Option	Description
Restore application size, position and selected content at startup	By default, Secure Copy starts in the state as you left it when you closed the application. Clear the check box if you want Secure Copy to start in the state in which it was installed.
Sort job list alphabetically	By default, the job list is sorted by creation time. Select this check box to sort the list alphabetically.
Show job option tooltips	By default, tooltips display on the job options pages when you hover the cursor over an option. Clear the check box to remove the display of the tooltips.
Turn on splash screen fading	By default, the Secure Copy product splash screen fades in and out when you start Secure Copy. Clear the check box to remove the animation when the splash screen displays.
Enable Secure Copy context menus	Select to display a Secure Copy menu in Windows Explorer when you right-click a folder, share, or file.

- 3 Click **OK**.

## Setting logging settings

There are two types of log files: Secure Copy logs and Tools logs for the Update Utilities. You can change the storage location for the log files, set the number of days to keep the log files, and select the type of errors to capture in the Update Utilities.

By default, Secure Copy logs are stored in the Secure Copy 7\Logs folder and Tools logs are stored in the Secure Copy 7\Logs\Tools folder. By default, the Update Utilities logs all errors and actions performed by users.

The log files can become unwieldy, so you may want to reduce the number of days log files are retained and change the type of errors logged.

### To modify logging settings

- 1 Select **Tools | Preferences**.
- 2 Open the **Logging Settings** tab.

You can change the location of the log files and the purge period for the Logs and Reports Repository and the Tools Log Repository.

**i** **NOTE:** For best performance, the repository should be stored locally. Data is written frequently to log files during Secure Copy jobs, and that data is accessed when reports are generated. Placing the Logs and Reports repository on a network path can negatively impact application performance.

- 3 To change the location of the log files, type a new path.
- 4 To change the purge period, select the check box, and choose a new value.
- 5 To change the types of errors logged by the Home Path Updater (HPU) and User Profile Updater (UPU), choose the depth of logging.
- 6 Click **OK**.

## Creating a basic job

To create a basic copy job, you just need to name the job, choose a source and target, and click **Run**.

### **To create a basic copy job**

- 1 Click **New**.  
-OR-  
Select **File | New**.
- 2 Type a name for the copy job. You can use any combination of alphanumeric characters to create a complete description.
- 3 Click **OK**. The copy job name displays in the **Jobs** list.  
**i** **NOTE:** To change the job name, select the name, and then choose **File | Rename**. Alternatively, right-click the job name, and then choose **Rename** from the shortcut menu.
- 4 Choose the path to the source and target.  
For the source, you can click **Import** to import a .TXT or .CSV file that contains multiple paths.  
The **Licensed Status** column uses a color code to indicate the status of the copy job.
  - **Green:** Path is licensed and there is no problem with the availability of licenses.
  - **Red:** Path is not licensed or does not exist and there are no more licenses available. You must correct the status to run the job successfully.
  - **Yellow:** Path is not licensed, but there are licenses available. When the job runs, a license will be consumed.
- 5 Change any settings. See [Changing basic copy job settings](#).
- 6 Click **Run**.  
-OR-  
Click **Run this job now** in the **Actions** area.

## Changing basic copy job settings

On the Job Summary page, you have a few settings that you can change quickly to customize the copy job.

### **To change basic job settings**

- Click the setting to toggle to the other setting. More options are available in the Jobs pane. See [Setting copy options](#).

Table 3. Basic copy job settings

Click to Toggle Setting	
<p><b>Copy changed files</b> Copy only changed files from the source to the target.</p>	↔ <b>Copy all files</b> Copy all files from the source to the target.
<p><b>do not synchronize</b> Contents of the target folder are not synchronized with the source.</p>	↔ <b>synchronize</b> Purge orphaned files and folders on the target. NOTE: To select additional options, click <b>Synchronization</b> in the Jobs pane. See <a href="#">Setting synchronization</a> .
<p><b>Do not send an email notification</b> Do not send an email notification when the copy job completes.</p>	↔ <b>Send an email notification</b> Send an email to the specified address. You are prompted to enter an email address. If you have not set SMTP settings, you are prompted to do so. NOTE: To select additional options, click <b>Email</b> in the Jobs pane. See <a href="#">Sending email notifications</a> .
<p><b>Ignore offline/stub files</b> Skip stub files during the copy process.</p>	↔ <b>Recall offline/stub files from source</b> Copy stub files, which results in recalling the original file from storage. NOTE: To select additional options, click <b>Other File Options</b> in the Jobs pane. See <a href="#">Setting other file options</a> .
<p><b>Do not migrate file shares</b> File shares are not migrated to a destination server.</p>	↔ <b>Migrate file shares</b> File shares are migrated to a target server. NOTE: To select additional options, click <b>File Shares</b> in the Jobs pane. See <a href="#">Migrating file shares</a> .
<p><b>Do not migrate local groups and users</b> Local groups and users are not migrated.</p>	↔ <b>Migrate local groups and users</b> Local groups and users are migrated from the source to the target. NOTE: To select additional options, click <b>Local Groups and Users</b> in the Jobs pane. See <a href="#">Migrating local groups &amp; users</a> .

## Selecting actions

Table 4. Actions for copy jobs

Click	To
Run this job now	Run the selected copy job. See <a href="#">Starting a copy job</a> .
Test this job	Test the selected copy job. See <a href="#">Starting a copy job</a> .
Schedule this job	Schedule the selected copy job. See <a href="#">Scheduling jobs</a> .
View job logs	Open the Logs and Reports page. See <a href="#">Viewing logs and reports</a> .

# Setting copy options

- About copy options
- Setting copy locations
- Setting synchronization
- Applying filters
- Setting performance options
- Maximizing copy performance
- Migrating local groups & users
- Migrating file shares
- Setting other file options

## About copy options

Copy options offer more options for the copy process. You can set basic options on the Job Summary page to perform a copy job quickly.

- i** **NOTE:** Secure Copy maintains job names and option settings in the SecureCopy.SSD file, which is located in the Secure Copy installation directory. If necessary, you can modify this file using a text editor, such as Notepad.
- NOTE:** After making changes, click **Save** to save the job. Alternatively, choose **File | Save** or right-click the job name, and choose **Save**.

## Setting copy locations

- i** **NOTE:** Secure Copy will transfer data between NTFS/FAT16/FAT32 partitions only (security will not be maintained when copying to a FAT partition). Secure Copy also transfers data from or to an Azure file share. Certain NAS appliance manufacturers have devices that are compatible with Secure Copy.

### **To set the copy locations**

- 1 Click **Jobs** and expand the job.
- 2 Click **Copy Locations**.
- 3 In the **Source Folders** area, click **Browse** to locate a path or click **Add** to type a path.

-OR-

If you have prepared a .TXT or .CSV file of paths, click **Import**, locate the file, and click **Open**.

- If you have a volume shadow copy service installed, select **Use volume shadow copy services on local source path to ensure open files are copied**. If a file is in use, the copy will continue.
- In the Target Folders area, click **Browse** to locate a path or click **Add** to type a path.

**i** | **NOTE:** If you type a path that does not exist, you are asked if you want to create it.

- By default, Secure Copy creates a folder structure on the target that mimics the folder structure in the source. To ignore the source folder structure, clear the **Create initial source folder under target folder** check box.

**i** | **IMPORTANT:** If the **Synchronize target contents with source** check box is selected on the Synchronization page, and you copy from multiple source paths, only those files in the last source file in the list are synchronized with the target. All other files in the target are deleted. See [Setting synchronization](#).

## Setting synchronization

There are several options you can choose to determine how the data is copied from the source to the target.

### To set synchronization

- Click **Jobs**, and expand the job.
- Click **Synchronization**.
- Set the options to determine how the data is copied.

Table 5. Copy options

Option	Description
Copy only changed source files to target	If the source and target have files with the same name, Secure Copy compares the file size and time/date stamp. If the file size is different or the target file is older than the source file, Secure Copy overwrites the target with the source. The target is not purged; files and folders that are in the target, but not in the source, remain in the target after the copy process completes. If the target path is empty, all files and folders are copied from the source to the target.
Overwrite target files even if they are newer than the source	Select to overwrite the target file even if the target file is newer than the changed source file.
Copy all files from source to target	If the source and target have files and folders with the same name, Secure Copy overwrites the target with the source. The target is not purged; files and folders that are in the target, but not in the source, remain in the target after the copy process completes. If the target path is empty, all files and folders are copied from the source to the target.

Table 6. Purge options

Option	Description
Synchronize target contents with source	Select to purge files during the copy process. For specific examples on using this option, see <a href="#">Synchronizing single source path to single target path</a> . <b>NOTE:</b> When purging files during the synchronization process, the source and target machines and paths as defined by the job must be compared, and then adjusted or purged accordingly. Because the purge requires the comparison of the source and target directories and files, the process could extend the duration of the data migration.

Option	Description
Purge orphaned files/folders on the target	<p>Select to make all files and folders in the target identical to those in the source. This option deletes files or folders in the target that also do not exist in the source.</p> <p><b>IMPORTANT:</b> Only select this option with a single source path and a single target.</p> <p><b>NOTE:</b> To move the deleted files or folders to the Recycle Bin, select the <b>Delete files or folders to the Recycle Bin</b> check box.</p> <p><b>IMPORTANT:</b> If the <b>Create initial source folder under target folder</b> check box on the <b>Copy Locations</b> page is not selected, the purge does not occur. See <a href="#">Setting copy locations</a>.</p> <p>If Source is <b>File share</b>, <b>Create source root share folder on target</b> check box on <b>File shares</b> page is not selected, the purge does not occur.</p>
Purge orphaned files/folders in SUBFOLDERS of the target	<p>Select to make all subfolders in the target identical to subfolders with the same name in the source. This option deletes files and folders in the target subfolders that also do not exist in subfolders with the same name in the source.</p> <p><b>IMPORTANT:</b> Only select this option with multiple source paths if you are certain that none of the source paths have subfolders with duplicate names.</p> <p><b>NOTE:</b> To move the deleted files or folders to the Recycle Bin, select the <b>Delete files or folders to the Recycle Bin</b> check box.</p>
Delete files or folders to the Recycle Bin	<p>Select to move the deleted target files and folders to the Recycle Bin.</p> <p><b>NOTE:</b> Only target files and folders on the local computer can be moved to the Recycle Bin.</p>
Filters	<p>Click to include or exclude specified files or folders from the purge. See <a href="#">Applying filters</a>.</p>

**Table 7. File attributes options**

Option	Description
Synchronize archive bit on source and target	Select to set the archive bit on the target folder or file to be the same as the source.
Clear archive bit on source after copying	Select to clear the archive bit on the source file after it is copied. Otherwise the archive bit will remain untouched.
Change Read Only attribute on copied files	Select to set or clear the Read Only attribute on all copied files.

**Table 8. Synchronization options**

Option	Description
Reset last accessed date on source files	Copying files and permissions causes the Last Accessed Date to be set to the current date. Select this option to change the Last Accessed Date to the date last accessed before the copy, which is useful if you want to later audit your files to see if they need to be archived or deleted.
Synchronize Last Accessed Date and Created Date on target files with source	<p>By default, the Last Accessed Date and the Created Date on the target files will be identical to the source.</p> <p><b>NOTE:</b> If you uncheck this option, the Last Accessed Date and the Created Date becomes the date the copy occurred.</p>

Option	Description
Synchronize Last Accessed Date and Modified Date on target folder with source	By default, the Last Accessed Date and the Modified Date on the target folder will be identical to the source. <b>NOTE:</b> If you uncheck this option, the Last Accessed Date and the Modified Date becomes the date the copy occurred.

**Table 9. Permissions options**

Option	Description
Don't copy permissions (copy data only)	Copying the permissions on data is not always necessary for every copy job. A user may just want to migrate data from one drive to another or from one server to another.
Always copy permissions, even on skipped files	Copies the permissions of source files and folders from the source to the target, even if the files and folders are exactly the same.  This option is helpful in a situation where the permissions were changed on the source, but the files were not modified. The copy process skips the files because of the file size and time/date stamp are identical. If this option is selected, the permissions are copied even if the file is not.
Filters	Specify selected groups or users to exclude or include in the copy process for permissions.  <b>To create a filter</b> <ol style="list-style-type: none"> <li>1. Click <b>Filters</b>.</li> <li>2. Click <b>Add</b>.</li> <li>3. Select the groups or users to include or exclude.</li> <li>4. Select the appropriate option: <ul style="list-style-type: none"> <li>• <b>DO NOT copy permissions for selected groups/users</b></li> <li>• <b>Copy permission ONLY for selected groups/users</b></li> </ul> </li> </ol> <b>NOTE:</b> To save the filter to a .csv file, click <b>Save</b> . You can load the saved filter file at a later time by clicking <b>Load</b> .
Override security on access denied (you must be an administrator)	Allows an administrator to perform a copy without changing any of the permissions or ownership for the objects.  In a traditional copy process, a user must have permissions on a file or folder to copy it. If the user is denied access, they must first take ownership of the object, and then set the appropriate permissions before copying it. Imagine the nightmare scenario of migrating 10,000 user home and profile directories from one server to another. These directories would take forever to repermission and copy.
Block inheritance for root folder(s)	Select to block inheritance on root folders. Blocking inheritance at the root of your target folder is designed to prevent permission changes made above the root of your target from overwriting any permission structures you migrate from your source.  <b>NOTE:</b> This check box is unavailable if the <b>Force inheritance for all target folder(s)</b> check box is selected.
Force inheritance for all target folder(s)	Select to force all the copied folders to keep their original permissions and to inherit the permissions from the target folder and the parent folder.

# Synchronizing single source path to single target path

When synchronizing the contents of the target folder with the source folder, you can select two different methods of purging orphaned files/folders in the target. These two options on the Synchronization page work in conjunction with the **Create initial source folder under target folder** check box on the Copy Locations page. See [Setting synchronization](#) and [Setting copy locations](#).

The examples included in this section illustrate how these three options work together.

- [Single source example 1](#)
- [Single source example 2](#)
- [Single source example 3](#)
- [Single source example 4](#)

## Single source example 1

### Selected Options

- Create initial source folder under target folder
- Synchronize target contents with source
  - Purge orphaned files/folders on the target

### Paths

Source Path	Target Path	Target Result
C:\SOURCE\	\\SRV1\C\$\TARGET\	\\SRV1\C\$\TARGET\SOURCE\

### Result

Because the **Create initial source folder under target folder** check box is selected, the source folder structure is duplicated under the target folder. When the copy process is complete:

- Files and folders in the target folder (\\SRV1\C\$\TARGET\SOURCE\) that do not also exist in the source folder (C:\SOURCE\) are purged from the target folder.

Figure 1. Orphaned folders and files on the target are purged

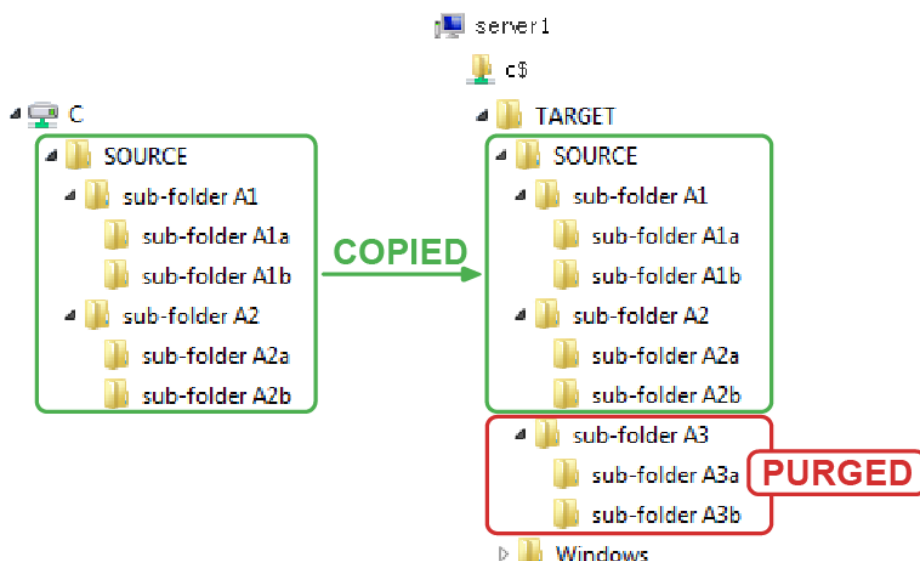

## Single source example 2

### Selected Options

- Create initial source folder under target folder
- Synchronize Target Contents with Source
  - Purge orphaned files/folders in SUBFOLDERS of the target

### Paths

Source Path	Target Path	Target Result
C:\SOURCE\	\\SRV1\C\$\TARGET\	\\SRV1\C\$\TARGET\SOURCE\

### Result

Because the **Create initial source folder under target folder** check box is selected, the source folder structure is duplicated under the target folder. When the copy process is complete:

- Files and folders that do not exist in the source folder (C:\SOURCE\) are not purged from the target folder (\\SRV1\C\$\TARGET\SOURCE\).
- Files and folders that do not exist in the first subfolders of the source folder (C:\SOURCE\subfolder A3) and down are purged from the corresponding target folder (\\SRV1\C\$\TARGET\SOURCE\sub-folder A3).

Figure 2. Orphaned subfolders and files on the target are purged

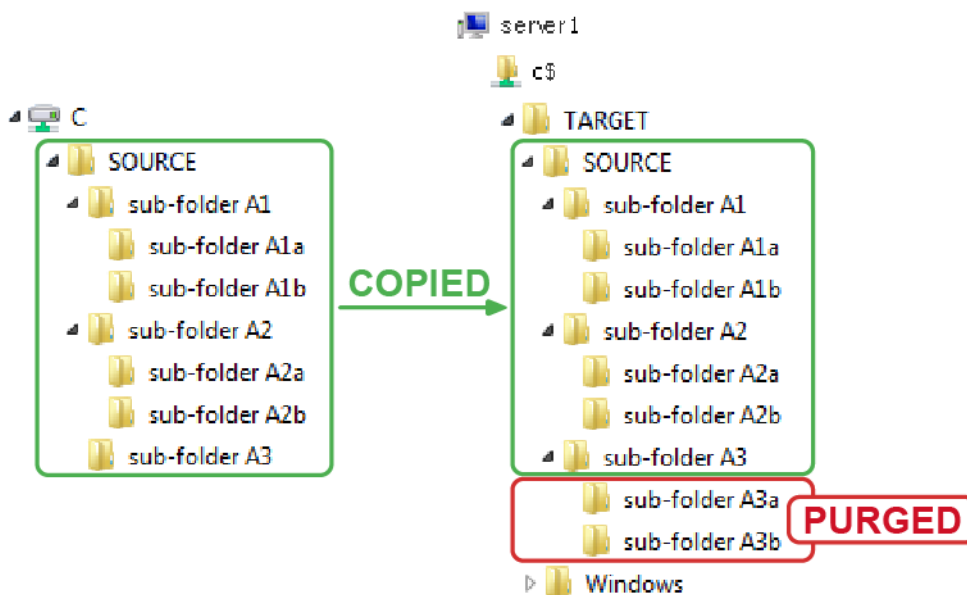

## Single source example 3

### Selected Options

- Create initial source folder under target folder
- Synchronize Target Contents with Source
  - Purge orphaned files/folders on the target

### Paths

Source Path	Target Path	Target Result
C:\SOURCE\	\\SRV1\C\$\	\\SRV1\C\$\

### Result

Because the **Create initial source folder under target folder** check box is not selected, the source folder structure is not duplicated under the target path. When the copy process is complete:

- All files and folders inside the source folder (C:\SOURCE\) are copied to the target folder (\\SRV1\C\$\).
- For safety, orphaned files and folders in this scenario are not purged because the system drive would be purged of all other data.

Figure 3. Orphaned folders and files on the target are not purged

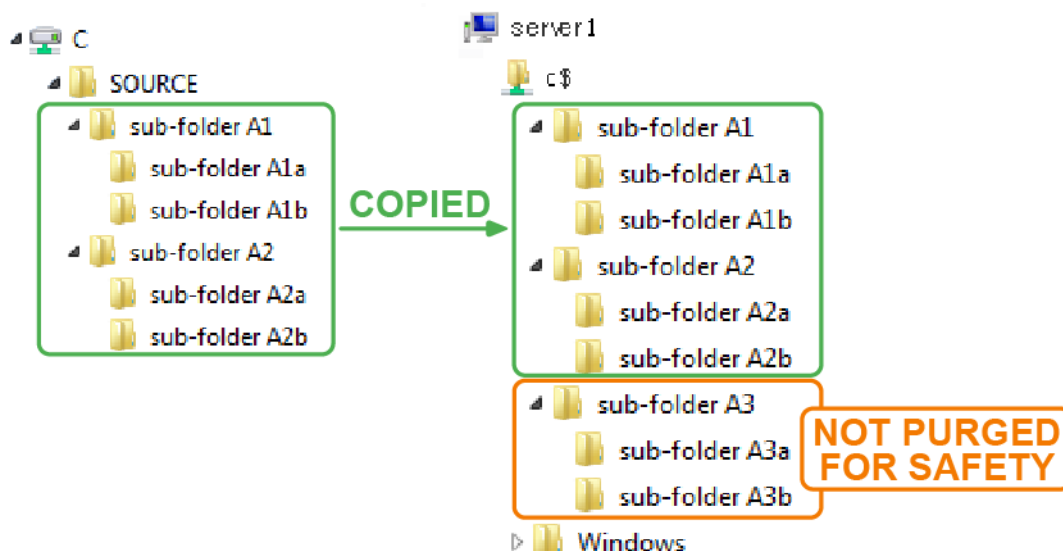

## Single source example 4

### Selected Options

- Create initial source folder under target folder
- Synchronize Target Contents with Source
  - Purge orphaned files/folders in SUBFOLDERS of the target

### Paths

Source Path	Target Path	Target Result
C:\SOURCE\	\\SRV1\C\$\TARGET\	\\SRV1\C\$\TARGET\

## Result

Because the **Create initial source folder under target folder** check box is not selected, the source parent folder is not duplicated under the target path, but the source subfolders are duplicated. When the copy process is complete:

- All files and folders inside the source folder (C:\SOURCE\) are copied to the target folder (\\SRV1\C\$\TARGET\).
- Files and folders that exist in the root of the source folder (C:\SOURCE\) are not purged from the target folder (\\SRV1\C\$\TARGET\).
- Files and folders that do not exist in the first subfolders of the source folder (C:\SOURCE\sub-folder A3\ and down are purged from the corresponding target folder (\\SVR1\C\$\TARGET\sub-folder A3).

Figure 4. Orphaned subfolders and files on the target are purged

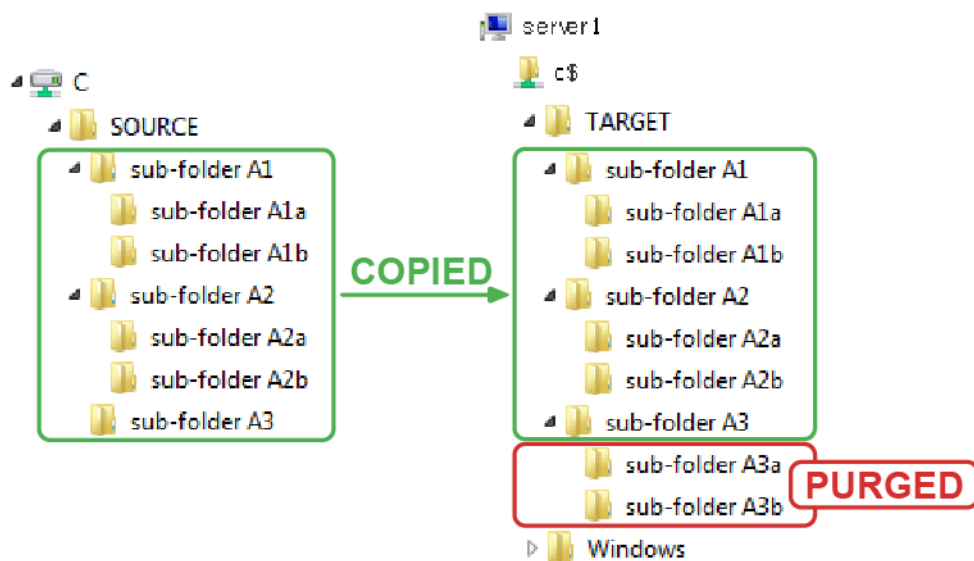

## Synchronizing multiple source paths to single target path

When synchronizing the contents of the target folder with the source folder, you can select two different methods of purging orphaned files/folders in the target. These two options on the Synchronization page work in conjunction with the **Create initial source folder under target folder** check box on the Copy Locations page. See [Setting synchronization](#) and [Setting copy locations](#).

**IMPORTANT:** When copying multiple source paths to a single target path, any file or folder with the same name located on the root of the source paths is overwritten by the file or folder of the same name in the last source path.

The examples included in this section illustrate how these three options work together.

- [Scenario 1: Folders with the same name](#)
- [Scenario 2: Files with the same name](#)
- [Multiple sources example 1](#)
- [Multiple sources example 2](#)
- [Multiple sources example 3](#)
- [Multiple sources example 4](#)

## Scenario 1: Folders with the same name

There are two folders named sub-folder B1; one is under the source path folder (C:\folderA) and the other is under the source path folder (C:\folderB). The sub-folder B1 folder from the last source path (C:\folderB\sub-folder B1) overwrites the sub-folder B1 folder from the first source path folder (C:\folderA\sub-folder B1). The target folder then contains only one sub-folder B1 folder, which contains the files and folders from the last source path folder (C:\folderB\sub-folder B1).

Figure 5. Copying folders with the same name

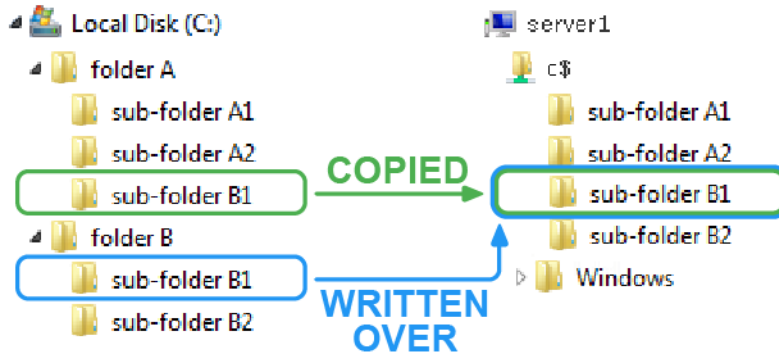

## Scenario 2: Files with the same name

There are two files named testfile.txt; one is under the first source path folder (C:\folderA) and the other is under the second source path folder (C:\folderB). The testfile.txt file from the last source path (C:\folderB\testfile.txt) overwrites the testfile.txt file from the first source path folder (C:\folderA\testfile.txt). The target folder then contains only one testfile.txt file (\server1\C\$\testfile.txt), which is the testfile.txt file from the last source path (C:\folderB\testfile.txt).

Figure 6. Copying files with the same name

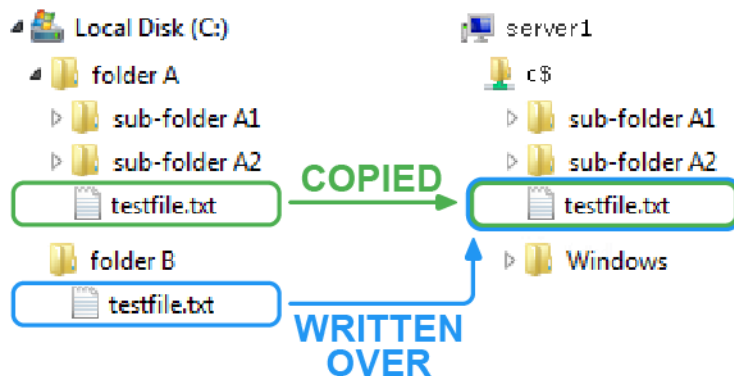

# Multiple sources example 1

## Selected Options

- Create initial source folder under target folder
- Synchronize Target Contents with Source
  - Purge orphaned files/folders on the target

## Paths

Source Path	Target Path	Target Result
C:\folderA\	\\server1\C\$\	\\server1\C\$\folderA\
C:\folderB\	\\server1\C\$\	\\server1\C\$\folderB\

## Results

Because the **Create initial source folder under target folder** check box is selected, the source folder structure is duplicated under the target path during the copy process. When the copy process is complete:

- All files and folders inside the source folders (C:\folderA\ and C:\folderB) are copied to the target folder (\\SVR1\C\$).
- Files and folders that do not exist in the source folders (C:\folderA\ and C:\folderB) are purged from the target folders (\\server1\C\$\folderA\ and (\\server1\C\$\folderB\).

Figure 7. Orphaned folders and files on target are purged

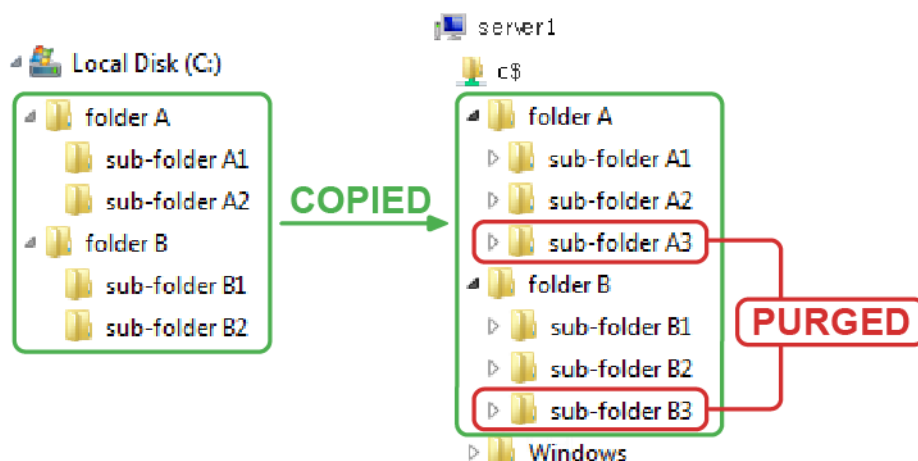

**i** **IMPORTANT:** When copying multiple source paths to a single target path, any file or folder with the same name located on the root of the source paths is overwritten by the file or folder of the same name in the last source path. See [Scenario 1: Folders with the same name](#) and [Scenario 2: Files with the same name](#).

## Multiple sources example 2

### Selected Options

- Create initial source folder under target folder
- Synchronize Target Contents with Source
  - Purge orphaned files/folders in SUBFOLDERS of the target

### Paths

Source Path	Target Path	Target Result
C:\folderA\	\\server1\C\$\	\\server1\C\$\folderA\ \\server1\C\$\folderB\ \\server1\C\$\folderA\sub-folderA1\ \\server1\C\$\folderA\sub-folderA1\sub-sub-folderA1a\ \\server1\C\$\folderA\sub-folderA1\sub-sub-folderA1b
C:\folderB\	\\server1\C\$\	\\server1\C\$\folderB\ \\server1\C\$\folderB\sub-folderB1\ \\server1\C\$\folderB\sub-folderB1\sub-sub-folderB1a\ \\server1\C\$\folderB\sub-folderB1\sub-sub-folderB1b

### Results

Because the **Create initial source folder under target folder** check box is selected, the source folder structure is duplicated under the target path during the copy process. When the copy process is complete:

- All files and folders inside the source folders (C:\folderA\ and C:\folderB) are copied to their respective target folders (\\server1\C\$\folderA\ and (\\server1\C\$\folderB\).
- Files and folders that do not exist in the root of the source folders (C:\folderA\ and (C:\folderB\)) are not purged from their respective target folders (\\server1\C\$\folderA\ and (\\server1\C\$\folderB\).
- Files and folders that do not exist in the subfolders of the source folders (C:\folderA\sub-folderA1\ and (C:\folderB\subfolderB1\)) and down are purged from their respective target folders (\\server1\C\$\folderA\sub1) and (\\server1\C\$\folderB\sub-folderB1).

Figure 8. Orphaned folders and files in subfolders on the target are purged

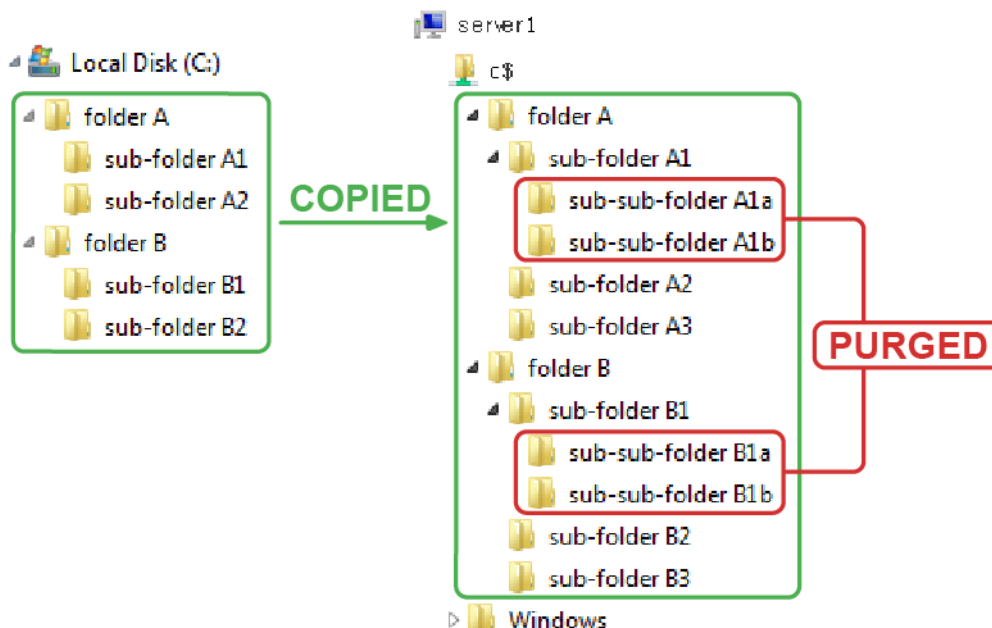

## Multiple sources example 3

### Selected Options

- Create initial source folder under target folder
- Synchronize Target Contents with Source
  - Purge orphaned files/folders on the target

### Paths

Source Path	Target Path	Target Result
C:\folderA\ C:\folderB\ 	\\server1\C\$\	\\server1\C\$\

### Result

Because the **Create initial source folder under target folder** check box is not selected, the source parent folder is not duplicated under the target path during the copy process, but the source subfolders are duplicated. When the copy process is complete:

- All files and folders inside the source folders (C:\folderA) and C:\folderB) are copied to the target folder (\\SVR1\C\$).
- For safety, files and folders that do not exist in the root of the source folders (C:\folderA) and (C:\folderB) are not purged from the target folder (\\SVR1\C\$), because the system drive would be purged of all other data.

Figure 9. Orphaned files and folders on the target are not purged

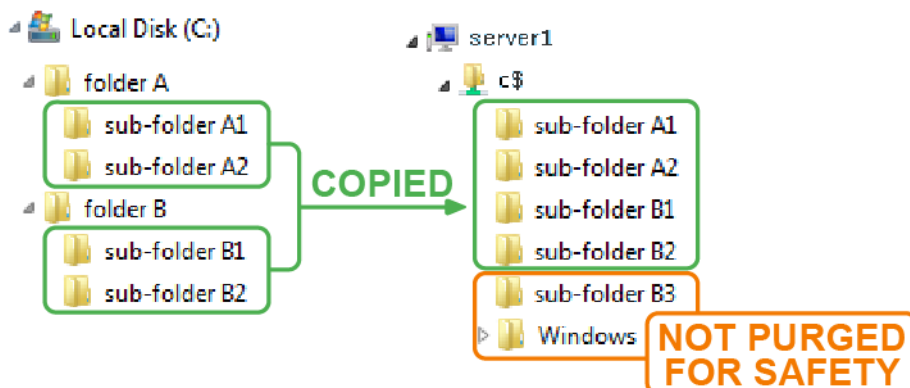

**i** **IMPORTANT:** When copying multiple source paths to a single target path, any file or folder with the same name located on the root of the source paths is overwritten by the file or folder of the same name in the last source path. See [Scenario 1: Folders with the same name](#) and [Scenario 2: Files with the same name](#).

## Multiple sources example 4

### Selected Options

- Create initial source folder under target folder
- Synchronize Target Contents with Source
  - Purge orphaned files/folders in SUBFOLDERS of the target

### Paths

Source Path	Target Path	Target Result
C:\folderA\ C:\folderB\ 	\\server1\C\$\	\\server1\C\$\

### Result

Because the **Create initial source folder under target folder** check box is not selected, the source parent folder is not duplicated under the target path during the copy process, but the source subfolders are duplicated. When the copy process is complete:

- Files and folders from all source paths are copied to the target folder (\\server1\C\$).
- Files and folders that do not exist in the first subfolders of the source folders (C:\folderA\sub-folder A1\ and C:\folderB\sub-folder B1\ and down) are purged from their respective target folders.
- For safety, files and folders that do not exist in the root of the source folders (C:\folderA\ and C:\folderB\ ) are not purged from the root of the target folder (\\server1\C\$).

Figure 10. Orphaned subfolders on the target are not purged

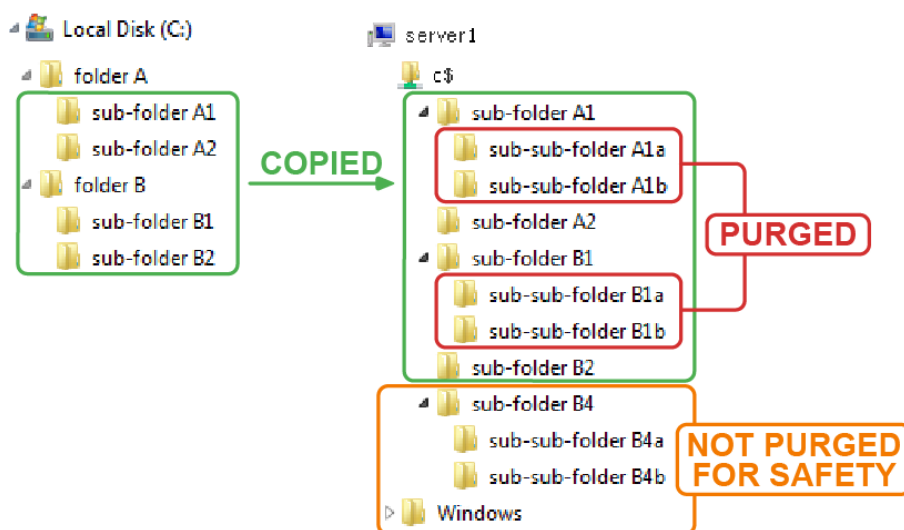

**IMPORTANT:** When copying multiple source paths to a single target path, any file or folder with the same name located on the root of the source paths is overwritten by the file or folder of the same name in the last source path. See [Scenario 1: Folders with the same name](#) and [Scenario 2: Files with the same name](#).

# Applying filters

Applying filters gives administrators control over what content gets migrated, which is especially useful for the elimination of files that may not be necessary or appropriate in a corporate environment, such as TMP, MP3, MOV, MPG, WMA or any hundreds of others. Conversely, applying filters can allow for migrations based on file types. For example, if one server will hold data such as multimedia for a company, a system administrator can specify that only the files for that use will go to the new server. In this case they might copy only JPG, MPG, SWF, MOV, WAV, or any other file with an extension that may be of importance.

Topics:

- [Filtering files](#)
- [Filtering folders](#)
- [Copying folder structures without files](#)

## Filtering files

You can filter files by file name or extension. You can create multiple filters, but you must add filters one at a time. In the following example, any files with the listed extensions are excluded from the copy job.

### To create a filter for files

- 1 Click **Jobs**, and expand the job.
- 2 Click **Filters**.
- 3 Select **Apply filter to the files**.
- 4 Click **Add**.
- 5 In the **Add Filter Name** box, type the characters to filter on, using the asterisk wildcard where needed.
  - To filter an extension, you must include an asterisk and a dot separator.  
**EXAMPLE:** \*.txt
  - To filter file names beginning with a specific string of text, use the filter STRING\*.  
**EXAMPLE:** TEST\* returns files such as TEST\_FILE.doc
  - To filter file names ending with a specific string of text, use the filter \*STRING.  
**EXAMPLE:** \*TEST returns files such as BOB\_FILE\_TEST.doc
  - To filter file names containing a specific string of text, use the filter \*STRING\*.  
**EXAMPLE:** \*TEST\* returns files such as BOB\_TEST\_FILE.doc
- 6 Click **OK**.
- 7 Repeat steps 2 through 4 to add more filters if necessary.
  - To delete a selected filter from the list, click **Remove**.
- 8 Select whether to include or exclude files based on the filter(s) listed in the **Filters** list.
- 9 To filter files by date created, modified, or last accessed, select **Filter Files by Specified Date**, choose the type of files to include, and choose the type of date range.
- 10 To filter files by size, select **Include files between these sizes**, and select the minimum and maximum sizes.
- 11 To filter sensitive content, select **Exclude files with sensitive content**. Browse to select the .csv file containing the sensitive content report.
  -  **NOTE:** This option requires a **Sensitive Content by Document** report exported by Metalogix Sensitive Content Manger 2.1 or later.
- 12 To save the filter to a .csv file, click **Save**.

- You can load the saved filter file at a later time by clicking **Load**.

## Filtering folders

In addition to filtering files, you can add a filter for folders. You can create multiple filters, but you must add filters one at a time. The asterisk wildcard is supported (New\* would filter a folder named New Folder). During a migration this might be helpful for the elimination of folders that are not necessary and can be recreated later. Some examples are temp folders and Temporary Internet Files folders.

### **To create a filter for folders**

- 1 Click **Jobs**, and expand the job.
- 2 Click **Filters**.
- 3 Select **Include/Exclude** folders.
- 4 Click **Add**.
- 5 In the **Add Folder Name** box, type the characters to filter on, using the asterisk wildcard where needed.
  - To filter out a specific folder, type the complete path to the folder, such as \\Server1\D\$\Finance\Invoices\.
- 6 Click **OK**.
- 7 Repeat steps 2 through 4 to add more filters if necessary.
  - To delete a selected filter from the list, click **Remove**.
- 8 Select whether to include or exclude folders based on the filter(s) listed in the **Folder names** list.
- 9 To filter folders by date created, modified, or last accessed, select **Filter Folders by Specified Date**, choose the type of folders to include, and choose the type of date range.
- 10 To limit the depth of the subfolders beneath the source folder that is selected for copy, select **Limit folder recursion depth**, and type a value to represent the level of subfolders (1 = one level; 2 = two levels).
- 11 To save the filter to a .csv file, click **Save**.
  - You can load the saved filter file at a later time by clicking **Load**.

## Copying folder structures without files

At times it may be desirable to replicate a directory structure from one computer to another, but not include files that may reside within that structure.

By using a combination of folder and file selection filters, it is possible to create a copy job that includes all the folders/directories of a specified source path, but does not include any files within that path.

### **To copy folders without files**

- 1 Click **Jobs**, and expand the job.
- 2 Click **Copy Locations**.
- 3 Specify the source and destination paths. See [Setting copy locations](#).
  - i** **NOTE:** When the source path is a drive root, such as \\server1\c\$, you may want to clear the **Create initial Source Folder Under Target Folder** check box on the Copy Locations page.
- 4 Open the **Filters** page.
- 5 Select **Include/Exclude folders**.
- 6 Leave the **Folder Names** list empty.
- 7 Select **Apply filter to the files**.

- 8 Click **Add**, type an extension that does not exist within the selected source structure, such as xyz, and then click **OK**.
- 9 Save and then run the job. See [Running a job](#).

## Setting performance options

The options on the Performance page affect the performance of the selected copy job. The selected options override the global options set with **Tools | New Job Options**. See [Setting default performance settings](#).

Topics:

- [Verifying file copy](#)
- [Enabling logging](#)
- [Maximizing copy performance](#)
- [Copying locked files](#)
- [Closing the Jobs Progress window](#)

## Verifying file copy

You can choose to compare an SHA512 checksum of the file being copied to the source and target.



**NOTE:** Verifying the file copy is a time, I/O, and processor intensive activity because it compares the checksums of the source and target files. Selecting this option could considerably extend the time required to complete the data migration.

**NOTE:** Use the File Verification Report to show errors in the SHA512 checksum comparisons. See [Running reports](#).

### *To verify the copy job*

- 1 Click **Jobs**, and expand the job.
- 2 Click **Performance**.
- 3 Select **Perform SHA512 checksum verification on copied files**.
- 4 To include skipped files, select **Include skipped files**.

## Enabling logging

You can set logging for an individual copy job. Two logging levels are available: **Full** and **Errors only**. Selecting **Full** automatically enables the **Logging Status** option where you can customize your logs by copying status.

### *To enable logging*

- 1 Click **Jobs**, and expand the job.
- 2 Click **Performance**.
- 3 Select **Enable logging**.
- 4 Select the logging level, and logging status (when available).

# Maximizing copy performance

By default, the number of files in a batch is 50, the size of the batch is 1 MB, the number of threads is 4, and the inter-packet gap is 0. The goal of adjusting these parameters is to maximize your network bandwidth. Other factors that prevent Secure Copy from using all the network bandwidth include slow disk speeds, disk fragmentation, and other activity on the network and file server.

## To maximize the performance of a copy job

- 1 Click **Jobs**, and expand the job.
- 2 Click **Performance**.
- 3 Adjust the thread count, batch count, batch size, and/or interpacket gap.

Table 10. Performance options

Option	Description
Thread count	<p>Select the number of copy threads for an individual copy job</p> <p>The number of threads is equivalent to the number of copy jobs that can be performed simultaneously. By increasing the thread count, you are adding more threads that copy batches of files. Each of the file threads deals with one batch of files at a time.</p> <p>In normal operation, the default settings should be adequate. However, if you have a large number of small files and many batches, you might start by creating at least 10 threads, and then monitoring network card utilization.</p> <p><b>IMPORTANT:</b> Setting the thread count too high can result in poor performance. We recommend using a value less than 20 if using normal server hardware.</p> <ul style="list-style-type: none"><li>• When moving a large number of small files, you can increase the number of threads towards the maximum number of 250 threads. With more threads per job, large numbers of files can be moved in the shortest period of time.</li><li>• When moving larger files, using fewer threads is more effective because the threads are able to focus on moving a few large files, switching control between few threads in a fluid process rather than passing control to multiple threads, which would slow down the copy process.</li></ul>
Batch count	<p>Select the maximum number of files in an individual copy job thread</p> <p>Batch Count is a limiter based on the number of files a thread can process at a time. When a job is being processed, a single thread copies either the maximum number of files in the batch count or the maximum batch size, whichever is reached first. The minimum number of files is 25 and the maximum is 1000.</p> <p><b>IMPORTANT:</b> In most cases, the default values are optimal. Changing these values incorrectly can lead to performance degradation.</p> <ul style="list-style-type: none"><li>• When processing a large number of small files, it is preferable to set the batch count to the highest level for efficiency.</li><li>• When processing large files, the batch count can be set anywhere because the batch size limitation will be met before the batch count limit is met.</li></ul>

Option	Description
Batch size	<p>Select the maximum number of bytes in an individual copy job thread.</p> <p>Batch Size is a limiter based on the size of the files a thread can process at a time. When a job is being processed, a single thread copies either the maximum size of files or the maximum number of files, whichever is reached first. The minimum is 1MB and the maximum is 100MB.</p> <p><b>IMPORTANT:</b> In most cases, the default values are optimal. Changing these values incorrectly can lead to performance degradation.</p> <ul style="list-style-type: none"> <li>• When processing a large number of small files, it is preferable to set the batch size to the highest level for efficiency.</li> <li>• When processing large files, the batch size can be set anywhere because the batch size limitation will be met prior to meeting the limit of the batch count.</li> </ul>
Inter-Packet Gap	<p>Select the time span to wait between packets of data being copied.</p> <p>The Inter-Packet Gap (IPG), which is also referred to as an Interframe Gap (IFG), slows down the copy process, which reduces the bandwidth usage over the network. As a file is copied, it is copied 64 kilobytes at a time. The Inter-Packet Gap is a time span in milliseconds (ms) to wait before sending the next 64 kilobytes.</p> <p><b>NOTE:</b> Due to factors, such as the volume of other traffic on the network, you may need to experiment with the time span to achieve a desired bandwidth.</p>

## Retrying on locked files or network errors

You can determine how many times a copy job retries to copy any files that were not copied during the initial pass through the directory structure, and how many times a copy job retries on network errors when the copy process starts.

### **To set the number of retries on a locked file**

- 1 Click **Jobs**, and expand the job.
- 2 Click **Performance**.
- 3 Select **Retry on locked file**.
- 4 Choose the number of times to attempt a retry on locked files.
- 5 Choose the number of minutes to wait between each retry on locked files.

### **To set the number of retries on network errors**

- 1 Click **Jobs**, and expand the job.
- 2 Click **Performance**.
- 3 Select **Retry on network error**.
- 4 Choose the number of times to attempt a retry on network errors.
- 5 Choose the number of seconds to wait between each retry on network errors.

## Closing the Jobs Progress window

When running a job, you can choose to close the copy window when no errors occur. If you want to keep the window open once you've selected the check box, clear the check box here.

### **To set the jobs progress window to close automatically**

- 1 Click **Jobs**, and expand the job.
- 2 Click **Performance**.
- 3 Select or clear **Close copy window automatically when no errors occur**.

## Migrating local groups and users

Secure Copy allows an administrator to recreate local groups and users on a target server if the local group or user has permissions on the data that is being copied. When the data is copied, the security shows a SID and an Account Unknown because the local storage area management (SAM) database on the target server does not have an entry for the local group/user on the source server.

**i** **NOTE:** Secure Copy migrates only local groups and users who already have permissions on the data that is being copied.

**NOTE:** When migrating a local group, Secure Copy sends an RPC call to the domain controller to validate the groups and the members of the group. In a standard single console migration, the group migration adds to the overhead and thus the time to complete the data migration. It is possible, when using multiple Secure Copy consoles that are each migrating data and thousands of local groups, each with hundreds of members, that Secure Copy can flood a domain controller with RPC requests generating RPC timeout errors.

### To migrate local groups and users

- 1 Click **Jobs**, and expand the job.
- 2 Click **Local Groups and Users**.
- 3 Select **Migrate local groups/users to destination server**.
- 4 Select what to migrate.

**Table 11. Migration options**

Option	Description
Local groups	Migrates local groups from the source to the target.
Local users	Migrates local users from the source to the target.
Copy only local groups and users not files	Migrates only local groups and users accounts. Files are not migrated. NOTE: Only local groups and users who already have permissions on the source data will be migrated.
Set password for migrated user accounts	Set a new password for the migrated user accounts. Type the new password in the box.

- 5 Select a destination for the migration.

**Table 12. Destination options**

Option	Description
Target server	Migrates local groups and users from the source server to the target server that is indicated on the Copy Locations page.
Active directory	Migrates local groups and users from the source server to an Active Directory® Organizational Unit (OU). Type a path using standard LDAP format in the box, or click <b>Browse</b> to browse for an OU.
Always perform the following action	To avoid conflicts, add a prefix or suffix to the migrated groups/users. Adding a prefix or suffix allows administrators to enforce a standard naming convention, or to differentiate the migrated groups and users from their already existing counterparts.

- 6 Select what to do if the Local Group/User name already exists.

Table 13. Existing local group/user options

Option	Description
Use the existing group/user	If a local group/user name already exists on the target, Secure Copy applies those permissions to the migrated data.
Add members of the source group to existing group	Migrates the users of a group on the source server to the group with the same name on the target server.
Synchronize target members with source members	If a local group/user already exists on the target, the source local group/user overwrites the target.
Add the Prefix Add the Suffix	In cases where there may be multiple local groups/users of the same name and manually renaming the local groups/users when prompted may be unfeasible, such as in the case of a scheduled job, you can have Secure Copy add a prefix or a suffix to the new local group/user name. This gives a uniform naming convention to the new local groups/users and prevents unnecessary user intervention.

- 7 To prevent Secure Copy from appending members to the target server's BUILTIN Groups, select **Don't append members to target server's BUILTIN groups**.
- 8 To use a map file to migrate local groups and users, see [Using map files to migrate local groups and users](#).

## Using map files to migrate local groups and users

A map file is a text file that creates a mapping between source and target groups and users. Using a map file gives you greater flexibility in the way that local groups/users are migrated.

Map files are used most commonly when local group/user accounts include the name of the source computer. For example, you need to migrate data from Server1 to Server2. Permission entries on the data include the local groups LocalGroup1\_Server1 and LocalGroup2\_Server1. If the data is copied using the Migrate Local Groups option, the data is copied to Server2, but the access control lists for the data still reference LocalGroup1\_Server1 and LocalGroup2\_Server1. Using a map file provides a means of modifying the behavior of the local group migration so that once the job completes, the access control lists for the data reference LocalGroup1\_Server2 and LocalGroup2\_Server2.

### To use a map file to migrate local groups and users

- 1 Using Notepad, create a map file by typing each name mapping on a new line.

```
SourceLocalGroup1=TargetLocalGroup1
SourceLocalGroup2=TargetLocalGroup2
SourceLocalUser1=TargetLocalUser1
SourceLocalUser2=TargetLocalUser2
```
- 2 Open Secure Copy.
- 3 Click **Jobs**, and expand the job.
- 4 Click **Local Groups and Users**.
- 5 Select **Migrate Local Groups/Users to Destination Server**.
- 6 Select **Specify Map File**, and click **Browse** to locate the map file.
  - To view or edit the contents of the map file, click **View**.
- 7 Select any other options on the Local Groups and Users page.
- 8 Open the Copy Locations page, and then specify the source and destination paths. See [Setting copy locations](#).
- 9 Save and then run the job. See [Starting a copy job](#).

# Migrating file shares

Secure Copy allows the migration of file shares from one server to another server or to multiple servers. Secure Copy recreates the file shares of the source server on the target server with share permissions intact, which greatly reduces the time for file share creation on the target server.

Shares whose folders are not specified in the source paths are not copied. In other words, as Secure Copy runs the copy process, it checks each source path and its subfolders to see if they are shared. If so, Secure Copy recreates the share on the target computer and creates the appropriate share permissions as dictated by those of the source.

The sub options are used if the share name already exists or if the share needs to be created.

## To migrate file shares

- 1 Click **Jobs**, and expand the job.
- 2 Click **File Shares**.
- 3 Select **Migrate file shares to destination server**.
- 4 Select how Secure Copy should handle shares if the share name already exists on the destination server.

Table 14. Existing share name options

Option	Description
Skip It (Ignore)	If a share already exists on the target, Secure Copy does not create the share on the target.
Overwrite (Remove old share, create new one)	If a share already exists on the target, Secure Copy unshares the share on the target, and then writes over it with the source share.
Add the Prefix Add the Suffix	Type the prefix or suffix to add to the new file share name. In cases where there may be multiple shares of the same name and you want to recreate the shares using the new folders from the source, but manually renaming the shares when prompted may be unfeasible, such as in the case of a scheduled job, you can have Secure Copy add a prefix or a suffix to the new share name. This gives a uniform naming convention to the new shares and prevents unnecessary user intervention.

- 5 If the source contains a root share folder, such as \\server\sharename, and you want to create that root share folder on the target, select **Create root share folder on target**. Otherwise, the root share folder is not created on the target.
- 6 If Source is **File share**, **Create source root share folder on target** check box on **File shares** page is not selected, the purge will not occur.

# Setting other file options

Topics:

- [Using map files to copy files and folders](#)
- [Copying encrypted files](#)
- [Copying off-line/stub files](#)
- [Copying recently modified files](#)
- [Using compression](#)
- [Copying ACL information](#)
- [Running Pre and Post Migration tasks](#)

# Using map files to copy files and folders

A map file is a text file that creates a mapping between source and target files and folders. Using a map file gives you greater flexibility in the way that files and folders are copied, either from one computer to another or to Active Directory®.

## Formatting Rules

- Source and target directory must be on different computers, copying from one location to another on the same computer (even if the source and target are on different volumes) prevents the folders from being mapped.
- The full path for the source and target folders must be entered into the map file.
- For folders, the source and target path in the map file must have a trailing backslash (not necessary for files).
- The target directory does not need to be created ahead of time. If the folder on the target directory does not exist prior to running the copy job, Secure Copy creates the target folder and copies the contents of the source folder into the new target folder.

## Examples

- To copy a file: `C:\test\testfile.txt=\\targetserver\test\testfile.txt`
- To copy folders: `C:\source\=\\ad3\e$\scy test\target\`
- To rename a file: `C:\test\testfile.txt=\\targetserver\test\newtestfile.txt`
- To divert a file: `C:\test\testfile.txt=\\targetserver\newDir\testfile.txt`
- To rename a folder: `C:\test\=\\targetserver\C$\newfolder\`

## To use a map file to copy folders and files

- 1 Using Notepad, create a map file by typing each name mapping on a new line.
- 2 Open Secure Copy.
- 3 Click **Jobs**, and expand the job.
- 4 Click **Other File Options**.
- 5 Select **Map Folders and Files**.
- 6 In the **Map File Path** box, type the path or click **Browse** to locate the map file.
  - To view or edit the contents of the map file, click **View**.
- 7 Click **Copy Locations**, and specify the source and destination paths. See [Setting copy locations](#).
- 8 Set any other copy options. See [Setting copy options](#).
- 9 Save, and run the job. See [Starting a copy job](#).

# Copying encrypted files

If Secure Copy cannot encrypt the copied file, you can choose to create an unencrypted file on the target. When copying a file that is encrypted on the source, Secure Copy attempts to encrypt the file on the target using the Encrypting File System (EFS). If Secure Copy is unable to encrypt the file on the target, the copy will fail unless this option is selected.

## To copy encrypted files

- 1 Click **Jobs**, and expand the job
- 2 Click **Other File Options**.
- 3 Select **Allow copy of encrypted files as unencrypted if encryption fails**.

# Copying off-line/stub files

By default, offline/stub files are skipped in a copy job. You can choose to copy files that are on an offline storage device, resulting in the original file being recalled from offline storage.

## To copy offline/stub files

- 1 Click **Jobs**, and expand the job.
- 2 Click **Other File Options**.
- 3 Select **Copy off-line files/stub files**.

# Copying recently modified files

By default, files where the last-modified date and time differs by less than 2 seconds are skipped in a copy job.

File-time granularity is 100 nanoseconds on NTFS and 2 seconds on FAT, so copying a file from NTFS to FAT causes file times to be rounded to a value that the FAT file system can manage. When both the source and destination volumes are NTFS, the file times are compared exactly. When either the source or destination volume is not an NTFS volume, Secure Copy considers file times to be identical if they are within 2 seconds of each other. Without this 2-second margin, Secure Copy might classify unmodified files as older or newer files, which would result in unnecessary copying of unchanged files.

Sometimes you may want to override this handling of file times. For example, you copy an NTFS tree to a FAT volume. Secure Copy rounds the file times. You then copy the FAT tree (with its rounded file times) to a local NTFS drive. Later, when you want to recreate the original tree exactly, you do not want to refresh the entire tree.

## To copy recently modified files

- 1 Click **Jobs**, and expand the job.
- 2 Click **Other File Options**.
- 3 Select **Ignore NTFS/FAT time differences up to 2 seconds**.

# Using compression

**i** **NOTE:** Compression is not performed by Secure Copy; it is performed by the operating system. The compression function is performed at the same time as the write function, which could extend the write time of the file and thus extend the duration of data migration.

## To use compression

- 1 Click **Jobs**, and expand the job.
- 2 Click **Other File Options**.
- 3 Select how to handle compression.

Table 15. Compression options

Option	Description
Never compress target files	Disregards any file or folder compression that may exist on the source or target. Copies all files and folders uncompressed. This option offers the greatest speed for the copy process, and is recommended if there is not a space requirement on the target.

Option	Description
Always compress target files	Select only in cases when space is a premium as it adds substantial overhead and time to the copy job. This option also adds to the fragmentation on the target volume. Use only if absolutely necessary.
Compress target files only if source is compressed	Select to compress the files and folders on the target if they are compressed on the source. This option provides consistency among the file systems on the source and target, but also adds to the time required to perform the process. Use only if necessary.

## Copying ACL information

During a migration, you can choose to update access control lists (ACLs) with new security identifiers (SIDs) for the objects being migrated and to remove their SID history.

### To update ACLs with new SIDs

- 1 Click **Jobs**, and expand the job.
- 2 Click **Other File Options**.
- 3 Select the options to update ACLs.

Table 16. ACL update options

Option	Description
Update ACLs which use SID history	Select to update ACLs that use SID history, and type a Lightweight Directory Access Protocol (LDAP) domain path.  During a migration, the SIDs of the objects being migrated are checked against the SID History specified in the LDAP domain path box. If the SIDs of the objects being migrated are on the list, the ACLs are updated with new SIDs for the migrated objects and their SID history is cleared.
Copy SACL	Select to copy security information.
Remove Orphaned SIDs	Select to remove orphaned SIDS.
Map SIDs Using Quest Migrator Pro or On Demand Migration map file	If you created a map file using Quest™ Migrator Pro or On Demand Migration, select the check box, and click <b>Browse</b> to locate the map file. <ul style="list-style-type: none"> <li>• To view the contents of the map file, click <b>View</b>.</li> <li>• By default, source permissions on the target are retained. If you do not want to retain the permissions, clear the <b>Leave source accounts permissions on target</b> check box.</li> <li>• If you want to copy only permissions for accounts that are included in the Migrator Pro or On Demand Migration INI map file and ignore all other permissions from the source, select <b>Translate only accounts found in the map file</b>.</li> </ul> <p><b>NOTE:</b> If you select <b>Translate only accounts found in the map file</b>, the <b>Leave source accounts permissions on target</b> check box is cleared and vice versa. Both checkboxes cannot be selected at the same time.</p>

## Running pre and post migration tasks

You can choose to run a task either before or after a migration.

- 1 In the **Jobs** pane, expand the job.

- 2 Click **Other File Options**.
- 3 Choose to run a task either before or after the migration.

**Table 17. Pre and post migration options**

Option	Description
Run a Pre-Migration Task	Select to run a task before the migration begins. Click Browse to locate an executable (*.exe or *.cmd) or type the path into the box.
Run a Post-Migration Task	Select to run a task after the migration completes. Click Browse to locate an executable (*.exe or *.cmd) or type the path into the box.
If a fatal error occurs, cancel all tasks including the migration.	Select to cancel all pending tasks and the migration if a fatal error occurs during the execution of a task or the migration.

## Sending email notifications

You can send an email notification when either a job has completed or has not completed by a specified date and time.

### To set up email notifications

- 1 Click **Jobs**, and expand the job.
- 2 Click **Email**.
- 3 Select **Send email notification**.
- 4 Select the condition on which the email notification is sent.

**Table 18. Email notification options**

Option	Description
When job completes	Select to send an email to the specified recipients when the copy job completes successfully.
If job has not completed by	Select to send an email to the specified recipients only if the copy job has not completed by the date and time specified. To change the date and time, click an item in the box, and then use the arrow keys to change the value.
If job is not completed within hh:mm:ss	Select to send an email to the specified recipients only if the copy job has not completed within the time period specified. To change the time period, click an item in the box, and then use the arrow keys to change the value.
If job fails	Select to send an email to the specified recipients if the job fails.

- 5 To add recipients, click **Add**, type the name of the recipient, and click **OK**. Repeat for each recipient.
- 6 Type the text to appear in the subject line of the email.

### To change the email settings for the copy job

- Click **Email Settings**. See [Setting SMTP settings](#).



**NOTE:** The SMTP settings override those set using **Tools | New Job Options | SMTP Settings**.

### To send reports with the email

- 1 Select **Attach job reports**.
- 2 Click **Select Reports**.
- 3 Select the reports to attach to the email.
- 4 Click **OK**. The number of reports you select displays on the **Email** tab.

By default, if the reports exceed 50 MB, the reports are not attached. To stop the attachment of the selected reports if the total size exceeds the value in the box, select **Do not attach reports if their total size exceeds x MB**, and enter a value.

# Running copy jobs

- Starting a copy job
- Restarting a copy job
- Importing a job
- Restoring job settings
- Scheduling jobs
- Managing scheduled jobs
- Viewing job status
- Viewing logs and reports
- Viewing copy job statistics
- Viewing log file contents
- Exporting logs
- Deleting logs
- Running reports
- Analyzing file systems statistics

## Starting a copy job

Once you have set up all the copy options, you can test and then run the copy job. Once the job has run, you can view statistics and run reports on the results. You also can schedule copy jobs to run at preset times.

**i** **NOTE:** Before running a job, click **Test** on the Tool Bar to test the job to see if any errors are generated. Alternatively, click **Test this job** on the Job Summary page, choose **File | Test**, or right-click a job in the Jobs list, and then choose **Test** from the shortcut menu. No files are copied during the test.

**NOTE:** To maximize the performance of Secure Copy, you can set various options on the Performance page to increase the number of copy threads used. See [Maximizing copy performance](#).

### **To run copy jobs**

- 1 Click **Jobs**.
- 2 Select one or more jobs.
- 3 Click **Run**.

-OR-

Click **Run this job now** on the Job Summary page, select **File | Run**, or right-click a job in the Jobs list, and then choose **Run** from the shortcut menu.

**i** **NOTE:** If you made any changes to the copy options, you are prompted to save the file before continuing.

The window opens to display the progress of the job.

- To cancel a job while it is running, click **Cancel**.
- If any errors occur during the job, an explanation and path displays. To save the errors to a comma/quote delimited log file (.txt), click **Save As**, locate a destination, name the file, and then click **OK**.

If the job is successful, a message displays in the window header.

- 4 If **Close this window automatically when no errors occur** is selected, the window closes if the job is successful; otherwise, click **Close**.

**i** **NOTE:** Once you select this option, the job progress window does not display again. If you want the window to display again, choose **Tools | New Job Options | Performance Settings** to reset the selection. See [Setting default performance settings](#).

## Restarting a copy job

If power is lost during a copy job, Secure Copy does not remember the last file it copied. You need to restart the job once power is restored. If the job is scheduled to run each night, the job will run at the next scheduled time.

If the copy job stops, you can restart the job without recopying the files already copied.

**i** **NOTE:** For the resume option, Secure Copy will generate more read requests against the storage. Thus, starting copy from scratch for very large volumes is recommended as an approach.

### To restart a copy job

- 1 Click **Jobs**, and expand the job.
- 2 Click **Synchronization**.
- 3 Select **Copy Only Changed Source Files to Target**.
- 4 Click **Run** to start the job again.

## Importing a job

You can create a new job quickly by using the options set for a current job and then importing a .csv file with the job name, source path, and target path.

### To import a copy job

- 1 Create a .csv file.

**FORMAT:** Job Name,Source Path,Target Path

#### EXAMPLES:

Copy Job 1,C:\folder 1\C:\folder2\

Copy Job 2,C:\source\,\\server1\targetshare\

Copy Job 3,\\server2\source\,\\server3\target\

**i** **IMPORTANT:** Do not put a space after the comma.

- 2 Choose **File | Import**.

- 3 Select a copy job with the options you want to use.
- 4 Click **Browse**, and choose the file to use.
- 5 Select if you want to schedule the job after the import is complete.
- 6 Click **OK**.

## Restoring job settings

Once you run a job, you can restore the settings for that job from the log file.

### *To restore job settings*

- 1 Click **Logs and Reports**.
- 2 Right-click a log file, and choose **Restore Job Settings**.
- 3 Open the **Settings** tab to view the settings associated with the job.
- 4 On the **Restore** tab, choose to restore the job settings to the job or to create a new job based on the settings.
- 5 If you chose to create a job, type a name for the job.
- 6 Click **OK**.
- 7 If you chose to restore the job, click **Yes** to overwrite the existing settings.

## Scheduling jobs

Secure Copy includes the ability to schedule copy jobs to occur when they are convenient to personnel, without interfering with business practices. The best time for data migration is during hours of non-operation or non-peak usage. Quite often this is not feasible for the average 9 to 5 administrator. Secure Copy uses the features of the Microsoft Task Scheduler service to handle all functions of job scheduling.

### *To schedule a copy job*

- 1 Select a job in the Jobs list, and click **Schedule**.  
-OR-  
Choose **File | Schedule**, or click **Schedule this job** on the Job Summary page.
- 2 Open the **Triggers** tab, and click **New**.
- 3 Define the conditions that will trigger the task.  
The task is enabled by default. You can set a time schedule, delay the start of the task, repeat the task, and stop the task if it is running for too long. You also can set the task to expire.
- 4 Click **OK**.
- 5 Open the **Actions** tab, and click **New**.
- 6 Define the action that will occur when the task starts. You can start a program, send an email, or display a message.
- 7 Click **Browse**, and locate the program or script to run.
- 8 Click **OK**.
- 9 Open the **Conditions** tab.
- 10 Define the conditions under which the task will run.

By default, the task will not run if the computer is on battery power. You can set the task to wait until the computer is idle for a period of time and if a network connection is available.

11 Open the **Settings** tab.

By default, the task runs on demand and stops if the task runs longer than 3 days. You can set additional criteria for running the task.

12 When you are finished setting up the scheduled task, click **OK**.

The task appears on the **General** tab. Once a job has run, it appears on the History tab.

## Managing scheduled jobs

The Task Scheduler service is included with Microsoft® Internet Explorer 5.0 and later with the Offline Browsing Pack installed.

### To view scheduled jobs

- Click **Start**, point to **Programs | Accessories | System Tools**, and then choose **Scheduled Tasks**.

## Viewing job status

The Job Status page displays the job name, the last date the job was run, and the job status.

### To view the status of a copy job

- On the Job Summary page, click **Job Status**.

By default, the Job Status page updates every 60 seconds. You can adjust the refresh rate or manually refresh the page by clicking **Refresh**.

## Viewing logs and reports

For each job run, Secure Copy automatically creates a log file (\*.scl), which is stored in the Quest\Secure Copy 7\Logs folder. The file name contains the date and time that the job was run.

### To view logs and reports

1 Click **Logs and Reports**.



**NOTE:** The Repository box displays the default location for log files. To choose a different Repository, click **Select**, and then choose a folder.

**NOTE:** For best performance, the repository should be stored locally. Data is written frequently to log files during Secure Copy jobs, and that data is accessed when reports are generated. Placing the Logs and Reports repository on a network path can negatively impact application performance.

**NOTE:** To change the default location for log files, choose **Tools | Preferences | Logging Settings**. See [Setting logging settings](#).

2 Select a log file from the **Logs and Reports** pane. The **Dashboard** tab displays a summary of the selected job.

## Viewing copy job statistics

### To view details about the selected copy job

1 Click **Logs and Reports**.

- 2 Select a log file from the **Logs and Reports** pane.
- 3 Open the **Summary** tab.

## Viewing log file contents

### To view the contents of the selected log file

- 1 Click **Logs and Reports**.
- 2 Select a log file from the **Logs and Reports** pane.
- 3 Open the **Logs Viewer** tab.

 **NOTE:** To display the contents of the **Log Viewer** tab as a report, open the **Reports** tab, and select **Verbose Report**.

## Filtering log file contents

You can filter the results by the values in the Level, Status, and Type columns, and you can group the results by the values in the Level, Logger, and Status columns.

Table 19. Options for filtering log file contents

Button	Description
Level	Filter the displayed results by the value in the Level column: All, Debug, Error, Fatal, Info, or Warn
Status	Filter the displayed results by the value in the Status column: All, Copied, Error, Info, Purged, or Stopped
Type	Filter the displayed results by the value in the Type column: All, dll, exe, htm, or wav
Group By	Group the displayed results by the values in the Level, Logger, or Status columns
Refresh	Reload the values from the log file
Clear	Clear all values from the display
Reset	Remove all groupings and filters from the displayed results
Export	Export log results to a CSV or XML file

## Exporting logs

You can export a log to a .CSV or .XML file.

### To export a selected log file

- 1 Click **Logs and Reports**.
- 2 Right-click a log file, and choose **Export**.
- 3 Choose the format for the file.
- 4 Click **Browse** to name the file and to choose a destination for the file.
- 5 Click **Save**.
- 6 Click **OK**.

# Deleting logs

Before you delete a log, you may want to export it to a file. See [Exporting logs](#).

## To delete a selected log file

- 1 Click **Logs and Reports**.
- 2 Right-click a log file, and choose **Delete**.
- 3 Click **Yes** to delete the log file.

# Running reports

You can run reports about the selected copy job.

## To run a report

- 1 Click **Logs and Reports**.
- 2 Select a log file from the **Logs and Reports** pane.
- 3 Open the **Reports** tab and select a report.

 **NOTE:** For those reports that can be sorted by Message or Source, select the desired option before running the report.

Table 20. List of reports

Report	Description
Summary Report	Lists job summary information.
Copied Files Report	Lists copied files, sorted by Message, Source, or File Type. <b>NOTE:</b> Select the method of sorting prior to running the report.
Skipped Files Report	Lists skipped files, sorted by Message, Source, or File Type. <b>NOTE:</b> Select the method of sorting prior to running the report.
Purged Files and Folders Report	Lists purged files and folders, sorted by Message, Source, or File Type. <b>NOTE:</b> Select the method of sorting prior to running the report.
Local Groups and Users Report	Lists migrated local groups and users.
Failed Job Report	Lists fatal errors that prevented the copy job from completing.
Errors Report	Lists errors, sorted by Message, Source, or File Type. Select the method of sorting prior to running the report.
File Verification Report	Lists any differences in the SHA512 checksum comparisons of file verification, if Verify File Copy is selected on the Performance page. See <a href="#">Verifying file copy</a> .
License Information Report	Lists licensed servers.
Console's Server List Report	Lists the server licenses used by this console.
Verbose Report	Displays the contents of the Log Viewer tab as a report.
Analysis Report	Displays the post-migration analysis.

# Analyzing file systems statistics

The File System Statistics Analyzer uses algorithms similar to Secure Copy to gauge both the scope and performance of the file systems of servers. In most cases, outputs from the analyzer are requested when performance issues are identified with Secure Copy. Extremely large file systems, poor communications between sources and targets, conflicts with other pieces of software, and other situations can cause the indexing performance of Secure Copy to suffer. One of the first elements of diagnosis in these situations is to try and gauge the overall size of the file systems configured for indexing.

## To analyze file systems statistics

- 1 Click **Analyze**.

-OR-

Choose **File | Analyze**.

- 2 Choose the item on which to collect statistics.
- 3 Table 21. List of reports

Report	Description
Enumerate all fixed drives on this computer	Select to gather statistics on all fixed drives on the computer.
Enumerate server	Select and type the name of the server on which to collect statistics.
Enumerate paths	Select and click <b>Browse</b> to locate a folder or click <b>Add</b> to type a folder name. You can add multiple paths to the list. <ul style="list-style-type: none"><li>• To remove a selected path, click <b>Remove</b>.</li><li>• To import a .TXT or .CSV file of paths, click <b>Import</b>, locate the file, and click <b>Open</b>.</li></ul>
Output File	The default output file is <b>C:\Program Files\Quest\Secure Copy 7\Logs\Outputlog.csv</b> . <ul style="list-style-type: none"><li>• To change the path or file name, click <b>Browse</b>.</li><li>• To view the contents of the output file, click <b>View</b>.</li></ul>
Threads	To change the number of threads, choose a different value. By default, 1 thread is used to perform enumeration. In some instances, target systems respond favorably to having more threads employed to enumerate file system information.
Use Backup Privileges	Select to leverage the Backup Operators right to avoid access denials in cases where no native rights exist to enumerate or read security information.
Capture Security Information	Select to force the application to read security from every resource encountered, in addition to recording file size and count information. Performance when using this option is generally much lower than without, but provides a much better indication of the performance of an Secure Copy agent used in the same scenario.
No SACL	Select to suppress the capture of system access control lists (SACL).
No status	Select to hide the command window and run the analyzer in quiet mode. <ul style="list-style-type: none"><li>• Click <b>Run</b>.</li><li>• To view the output file, click <b>View</b>.</li></ul>

# Using the command line

- [Using SecureCopyCmd.exe](#)
- [Using Analyzer from the command line](#)

## Using SecureCopyCmd.exe

You can run Secure Copy from the command line by using SecureCopyCmd.exe. You can run the File System Statistics Analyzer from the command line using FileSystemStatistics.exe.

SecureCopyCmd.exe is the engine that Secure Copy uses for copy processes and it uses all of the features that are available in Secure Copy. SecureCopyCmd.exe runs from the command line, but offers only limited options to script, because it references the features of a saved job by using the name of that job.

**i** **NOTE:** You must use SecureCopyCmd.exe from a computer that has a fully licensed version of Secure Copy 7 installed. You cannot copy SecureCopyCmd.exe from computer to computer.

### Usage

SecureCopyCmd.exe

**Table 22. Parameters for SecureCopyCmd.exe**

Parameter	Meaning
/DB	Specify jobs database (.ssd file)
/Name=<Name>	Specify job using Job Name
/Source=<SourcePath>	Define a new source path. <b>IMPORTANT:</b> If you add /source to the command, it overrides the source(s) specified in the copy job identified by the job id or name.
/Target=<TargetPath>	Define a new target path. <b>IMPORTANT:</b> If you add /target to the command, it overrides the target(s) specified in the copy job identified by the job id or name.
/CopySubFolders=<True/False>	Specify true or false.
/Test	Test the job.
/Delete	Delete the job.
/Quiet	Runs job without user interface.

## Examples

```
securecopycmd.exe /Name=Default /Test
securecopycmd.exe /Name=Default /Delete
securecopycmd.exe /Source=c:/CBrown/My Documents /Target=c:/Backup/My Documents
```

# Using Analyzer from the command line

You can run the File System Statistics Analyzer from the command line using `FileSystemStatistics.exe`, which is located in the Secure Copy 7 installation folder.

## Usage

The File System Statistics Tool (`FileSystemStatistics.exe`) is located in the Secure Copy installation folder: `C:\Program Files\Quest\Secure Copy 7`.

```
FileSystemStatistics /roots <roots> | /server <server> /out <filename> [/threads <count>] [/security] [/nobackup] [/nostatus]
```

If neither `/roots` or `/server` are specified, the application will enumerate all fixed drives on the local computer, and process them.

**Table 23. Required Arguments**

Required Argument	Meaning
<code>/roots &lt;roots&gt;</code>	A list of semi-colon separated paths to scan. This parameter must be specified. If there are any spaces in the paths, entire list of roots should be in quotes.
<code>/server &lt;server&gt;</code>	The name of the server to process. When specified, all normal <non administrator, non IPC> shares are enumerated and used as roots.
<code>/out &lt;filename&gt;</code>	A file in which to write the applications output. The data written to this file is in comma separated (csv) format and is suitable for import into Microsoft Excel.

**Table 24. Optional Arguments**

Optional Argument	Meaning
<code>/threads &lt;count&gt;</code>	The number of threads to use to perform the enumeration. The number of threads must be less than or equal to the number of roots specified, so as to ensure that each one can be given roots to process. If not specified, 1 thread is used.
<code>/nobackup</code>	Avoids the use of the backup rights. If this flag is not specified, the backup right is enabled. Note that backup rights must be held on both the server where this application is run, and the target server.
<code>/security</code>	Instructs the application to capture security information in addition to count and size information.
<code>/no status</code>	Suppresses the command window and runs the tool in quiet mode.

### Example: retrieving information for all shares

```
FileSystemStatistics /server SERVERNAME /out ServerName-outputfile.csv
```

### Example: Retrieving information for a set of shares

```
FileSystemStatistics.exe /roots "\\SERVERNAME\Share1;\\SERVERNAME\Share Number 2" /out ServerName-outputfile.csv
```

---

# Managing licenses

- [Viewing licenses](#)
- [Viewing licensed servers](#)
- [Applying a new license file](#)
- [Checking for product updates](#)

## Viewing licenses

Secure Copy is licensed per server or per user. When you create a copy job, Secure Copy checks the license status to verify that the selected servers are on the list of licensed servers or if you have an available license to add the server. Use the options on the Help menu to monitor your license.

License details include the license number, license type, expiration date, and the number of licensed servers and users. To see how many of the licensed servers are being used, check the list of licensed servers.

### **To view license details**

- Choose **Help | About**, and then open the Licenses tab.  
-OR-
- Choose **Help | License Status**, select a license, and click **Details**.

## Viewing licensed servers

If a console is not on the list of servers, Secure Copy automatically adds it to the list when you run a copy job.

### **To view a list of licensed servers**

- 1 Choose **Help | Licensed Servers**.
- 2 To print a list of the console's licensed servers, click **View Report**. Alternatively, run the Console's Server List Report on the Reports tab of the Logs and Reports page. See [Running reports](#).

# Applying a new license file

## *To apply a new license file*

- 1 Choose **Help | License Status**.
- OR–  
Click **License Status**.
- 2 Select a product feature, and click **Update License**.
- 3 Locate the Quest™ license file (\*.asc or \*.div), and click **Open**.

# Checking for product updates

Secure Copy checks for updates to the software when you start the application, but you also can check for updates manually.

## *To manually check for updates*

- Choose **Help | Check for Updates**.

# Running Update Utilities

- [Home Path Updater](#)
- [Profile Path Updater](#)
- [Shortcut Updater](#)
- [Link Updater](#)
- [Link Updater for Access](#)
- [Registry Updater](#)

## Home Path Updater

The Home Path Updater allows you to update user home directory paths after you have migrated data to a new server. You can update the users in a domain, which may span several servers, and map their home directory paths to one or more new servers.



**IMPORTANT:** Your logon account must have administrative rights for the domain in which the user accounts exist.

**NOTE:** Home Path Updater and Profile Path Updater require that Active Directory® Users have Home Paths and Profile Paths configured in Active Directory, otherwise when the domain is scanned, the Server drop-down list will be empty.

### *To update user home directory paths*

- 1 Click **Update Utilities** in the Navigation Pane, and then click **Home Path Updater**.

To suppress the User Home Path Updater Wizard Welcome page, clear the **Always show Welcome screen** check box to hide this screen the next time you start the updater.

- 2 Click **Next**.
- 3 Select the type of update that you want to create.

You can create a new update or import a .CSV file that you previously exported. When you create a new update, you have the opportunity to export the definition to a .CSV file.

- 4 Click **Next**. If you imported a previously-exported file, go to step 6.

- 5 If you are creating a new update:

- a. Select a domain.
- b. Select a server.

By selecting a specific server you can filter the list of users to include only those users that have a home drive on the specified server. This feature is useful if you have just migrated those directories to a new server.

- c. Select the users in the specified domain you want to update. The user accounts can reside on one or more servers.



**NOTE:** Active Directory® Users must have Home Paths configured in Active Directory, otherwise when the domain is scanned the Server list will be empty.

**TIP:** If you use **Add All** to select all the users listed, you can then use **Remove** to selectively remove individual users who you do not want to update.

- d. Click **Add**.
  - e. Click **Next**.
  - f. Map the source servers to the new target servers that will replace the source servers in the users' home directory paths.  

The Home drive mappings page lists all of the servers on which the selected users have their home drives: these are the source servers. You can map each source computer to a different target computer or you can map multiple source computers to a single target computer.
  - g. Click the row that contains the source computer to be mapped.
  - h. Browse to select a target computer.
  - i. Repeat for each source computer to be mapped to a new target computer.
  - j. Click **Next**.
- 6 View the details for the user home paths that you are updating and make individual changes to the new home path information, if necessary.
- To edit specific information, click the entry under the New Home Dir heading that you want to change, and enter in the changes.
  - To make changes for several users at a time, **click Replace All** and enter the information to be changed and the new information that replaces it.
- 7 Export the user home path mapping details to a file, if desired. The file that is created is in .csv (comma-separated values) file format.

A .csv file is a method to collect data so that it can be used as input for a table-oriented application such as a spreadsheet. Microsoft Excel can read .csv files. By editing the .csv file, you can make bulk changes to the user information using search and replace options.

#### **To export the file**

- a. Click **Export** to create a file.
- b. Enter the name for the file and the location in which it should be saved.
- c. Click **Save**.

After you have created the file, you can import it into a program such as Microsoft Excel and make bulk changes to the user information using search and replace options. You can then import the file into this wizard and update the user home paths on the specified servers.

After you import the file into a program such as a spreadsheet application, you can see that the file follows certain conventions that must be maintained as you edit the file:

- The first column and row must contain the domain name.
- The subsequent rows that contain the user home path details must be in the following format:

user name	current user home path	new user home path	drive letter
-----------	------------------------	--------------------	--------------

- 9 Click **Next**.
- 10 Review the final information for the user home path updates.
- 11 Click **Finish**.

While the update is running, the User Home Path Updater displays a dialog box that shows the statistics for the update, such as the elapsed time and the estimated time remaining. You can also use this dialog box to stop the update.

For an easy way to verify that the user home paths have been updated, run the User Home Path Updater again and select the target server from the previous update on the Select Users page of the wizard. All of the users that you updated are now listed under the target server. Once you have viewed the list, close the wizard.

# Profile Path Updater

The User Profile Path Updater allows you to view roaming user profiles on a server within a specified domain and to update the paths after you have migrated data to a new server. A roaming user profile is stored on a server and is available every time an end user logs on to any computer on the network. Any change made to the roaming user profile is updated on the server.

**i** **IMPORTANT:** Your logon account must have administrative rights for the domain in which the user accounts exist.

**IMPORTANT:** Home Path Updater and Profile Path Updater require that Active Directory® Users have Home Paths and Profile Paths configured in Active Directory, otherwise when the domain is scanned the Server drop-down list will be empty.

## To update the path of a roaming user profile

- 1 Click **Update Utilities**, and click **Profile Path Updater**.

To suppress the User Profile Path Updater Wizard Welcome page, clear the **Always show Welcome screen** check box to hide this screen the next time you start the updater.

- 2 Select the type of update that you want to create.

You can create a new update or import a .CSV file that you previously exported. When you create a new update, you have the opportunity to export the definition to a .CSV file.

- 3 Click **Next**. If you imported a previously-exported file, go to step 5.

- 4 If you are creating a new update:

- a. Select a domain.
- b. Select a server.

By selecting a specific server you can filter the list of users to include only those users that have a home drive on the specified server. This feature is useful if you have just migrated those directories to a new server.

- c. Select the users in the specified domain you want to update. The user accounts can reside on one or more servers.

**i** **NOTE:** Active Directory Users must have Home Paths configured in Active Directory, otherwise when the domain is scanned the Server list will be empty.

**TIP:** If you use **Add All** to select all the users listed, you can then use **Remove** to selectively remove individual users who you do not want to update.

- d. Click **Add**.
  - e. Click **Next**.
  - f. Map the source servers to the new target servers that will replace the source servers in the users' home directory paths.

The Home drive mappings page lists all of the servers on which the selected users have their home drives: these are the source servers. You can map each source computer to a different target computer or you can map multiple source computers to a single target computer.
  - g. Click the row that contains the source computer to be mapped.
  - h. Browse to select a target computer.
  - i. Repeat for each source computer to be mapped to a new target computer.
  - j. Click **Next**.
- 5 View the details for the user profile paths that you are updating and make individual changes to the new profile path information, if necessary.
    - To edit specific information, click the entry under the New Profile Path heading that you want to change and enter in the changes.

- To make changes for several users at a time, click **Replace All** and then enter the information to be changed and the new information that replaces it.
- 6 Export the user profile path mapping details to a file, if desired. The file that is created is in .csv (comma-separated values) file format.

A .csv file is a method to collect data so that it can be used as input for a table-oriented application such as a spreadsheet. Microsoft Excel can read .csv files. By editing the .csv file, you can make bulk changes to the user information using search and replace options.

- a. Click **Export** to create a file.
- b. Enter the name for the file and the location in which it should be saved.
- c. Click **Save**.

After you have created the file, you can import it into a program such as Microsoft Excel and make bulk changes to the user information using search and replace options. You can then import the file into this wizard and update the user profile paths on the specified servers.

After you import the file into a program such as a spreadsheet application, you can see that the file follows certain conventions that must be maintained as you edit the file:

- The first column and row must contain the domain name.
- The subsequent rows that contain the user profile path details must be in the following format:

user name	current user home path	new user profile path	drive letter
-----------	------------------------	-----------------------	--------------

- 8 Click **Next**.
- 9 Review the final information for the profile path updates on the Confirmation page.
- 10 Click **Finish**.

While the update is running, the User Profile Path Updater displays a dialog box that shows the statistics for the update, such as the elapsed time and the estimated time remaining. You can also use this dialog box to stop the update.

For an easy way to verify that the user profile paths have been updated, run the User Profile Path Updater again and select the target server from the previous update on the Select Users page of the wizard. All of the users that you updated are now listed under the target server. Once you have viewed the list, close the wizard.

## Shortcut Updater

Use the Shortcut Updater to update shortcuts to point to the new location after data is migrated to a new server. When you run the Shortcut Updater, the shortcut files (.lnk) that contain the shortcut paths to the source computer are updated to point to the new target path location.

You can specify the old and new target path of the shortcut or use a .INI file. The .ini file must be saved in ANSI-encoded format.

### Example

You migrated data from server CORP1\_NT to server CORP1\_2K. During the migration, you renamed Accts to Accounts and Sales to UKSales. The .ini file to update those shortcuts that map to files and folders on the old server is:

```
[ServerMap]
\\CORP1_NT\Sales = \\CORP1_2K\UKSales
\\CORP1_NT\Accts = \\CORP1_2K\Accounts
\\CORP1_NT = \\CORP1_2K
```

### To update shortcuts

- 1 Click **Update Utilities**, and click **Shortcut Updater**.
- 2 Type the path or browse to locate the path of the shortcut files to update.

- 3 To include subdirectories in the path, select **Include Subfolders**.
- 4 Specify the source path and target path for the shortcut update or use a .INI file.

**To specify a path**

- a. Type the path or browse to locate the path of the old target of the shortcut.
- b. Type the path or browse to locate the path of the new target of the shortcut.

**To use a .INI file**

- a. Select Use Ini File.
- b. Type the path to the .ini file that contains the path update information.

- 5 To run a test on the update, select **Run As a Test**.

The test report audit displays the number of shortcuts that will be updated by Shortcut Updater. No shortcuts are actually updated when you run the test report. Specify the number of shortcut files to include in the test. If you leave the box blank, the default is 500 files.

- 6 Click **Run**.

Upon completion, the Shortcut Updater creates a log file and a report file in the Tools subfolder (C:\Program Files\Quest\Secure Copy 7\Logs\Tools\Shortcut Updater).

Format for the file name: SU\_ddmmyy\_hh\_mm\_ss.\*

- To view the report in a web browser, click **Report**. You also can open the report from the Navigation pane by double-clicking the report file name.
- To view the log, click **Log**. You also can open the report from the Navigation pane by double-clicking the log file name.

- 7 When you are ready to perform the update, clear the **Run as a Test** box, and click **Run**.

## Link Updater

**i** **IMPORTANT:** Microsoft Office is required for Link Updater. Do not run Microsoft Office applications on the computer on which the Link Updater is running. If you have Excel open when you run Link Updater, Excel will be forcibly closed with no prompting to save your files.

You can use the Link Updater (LU.exe) to update OLE (Object Linking and Embedding) links and hyperlinks in Microsoft Word, Excel, and PowerPoint files that have been migrated to a new server.

**i** **NOTE:** The Link Updater cannot update the links in files that are password protected or to which access is denied and files that are in use.

The OLE links and hyperlinks can use either UNC (Universal Naming Convention) paths or explicit local paths. The utility can update the existing links in a document to new local paths or UNC paths as necessary.

In a network, the Universal Naming Convention (UNC) is used to identify a shared file in a computer without having to specify the specific storage device on which it is located. In Windows® operating systems, the UNC can be used instead of the local naming system. The UNC name format is as follows:

```
\\servername\sharename\path\filename
```

A UNC path cannot contain any folder names or subfolder names since the file name could already exist directly under the share name.

### Prerequisites

Before you update the link information, verify that the following prerequisites are met:

- Microsoft Word, Excel, and PowerPoint must be installed on the computer on which the Link Updater is run.
- You must be logged on with an account that has administrative rights since you need access to the files.

## To update links

- 1 Click **Update Utilities** In the Navigation Pane, and then click **Link Updater**.
- 2 In the Scan Path box, type a path or browse to locate the Microsoft Word, Excel, or PowerPoint files that contain links you want to update.
- 3 You can specify the source path and target path for the shortcut update or use an .INI file.

 **NOTE:** The link updater verifies that the target folder exists before it updates the links.

### To specify a path

- a. In the **Source Link** box, type a path or browse to locate the linked files on the source computer. The path name can be a local path or UNC path.
- b. In the **Target Link** box, type a path or browse to locate the linked files on the target computer. The path name can be a local path or UNC path.

### To use a map file

- a. Select **Use Map File**.
  - b. Type a path or browse to locate the link map .ini file that maps the old locations of linked files to the new locations. See [Creating a link map .ini file](#).
  - c. Click **Open**.
- 4 Set options for the update.

Table 25. Update options

Option	Description
Recursive Search and Update	Select to search recursively through the folders and subfolders of the paths you have specified.
Turn on output to CSV file	Select to save detailed information from the test report in a CSV (comma separated values) file.
Log detailed info	Select to save detailed information from the update in a log file.

- 5 To perform a test report audit to see the number of files that will be updated by Link Updater, select **Test Mode**, and specify the number of files you want to test. No files are actually updated when you run the test report.
- 6 Click **Run**.

Upon completion, the Link Updater creates a log file and a report file in the Tools subfolder (C:\Program Files\Quest\Secure Copy 7\Logs\Tools\Link Updater).

Format for the file name: LU\_ddmmyy\_hh\_mm\_ss.\*

### To view the report in a web browser

- Click **Report**. You also can open the report from the Navigation pane by double-clicking the report file name.

### To view the log

- Click **Log**. You also can open the report from the Navigation pane by double-clicking the log file name.

- 7 When you are ready to perform the update, clear the **Test Mode** check box, and click **Run**.

# Creating a link map .ini file

Information in an .ini file is grouped by section headers, which are names that are enclosed in brackets such as [SectionName]. The section header defines what the section represents. The data to be updated is specified after the [SectionName]. Use the section header [LinkMap] in an .ini file used with the Link Updater.

The .ini file must be saved using ANSI encoding. The file can be edited with a text editor or a word processor that imports ASCII files.

The target path must include the folder in which the files now reside. For example, the .ini file content for remapping the location information for the OLE links in files might look as follows:

```
[LinkMap]
C:\Corporate\HR Docs = G:\Corporate\HR Docs\Excel
D:\Documents = G:\Documents
```

**i** **NOTE:** Do not enclose any file or folder names that contain spaces in quotation marks in an .ini file. You only use enclose variables in quotation marks in the command line.

## Example

You have a Microsoft Word file with links to different types of files in several different folders. You have created an .ini file that maps the old locations of the linked files to the new locations. The name of the .ini file is remap.ini and is located in C:\Migration.

```
LU "\\ServerA\Sales 2005\Company X RFP.doc" /F=C:\Migration\remap.ini
```

# Running Link Updater from the command line

The Link Updater (LU.exe) is located in: C:\Program Files\Quest\Secure Copy 7\Tools.

You should only run the Link Updater during a time when users do not need to access files on the server or when it is possible for you to lock out all users and prevent them from accessing files on the server. You must run the LU.exe file from the Secure Copy server because of the licensing check the file performs.

**i** **IMPORTANT:** Do not run Microsoft Office applications on the computer on which the Link Updater is running.

Use the following syntax to run Link Updater from the command line and manually specify the paths to be updated:

```
LU FullFilePath SourcePath TargetPath [/r] [/t= n] [/c] [/z]
```

**Table 26. Required Parameters**

Required Parameter	Meaning
FullFilePath	Location of the Microsoft Word, Excel, or PowerPoint files that contain links you want to update. Enter as the full path name to the directory that contains the files followed by \*. * (which is the default). <ul style="list-style-type: none"><li>• To update only Microsoft Word files, specify *.doc in the path name.</li><li>• To update only Microsoft Excel files, specify *.xls in the path name.</li><li>• To update only Microsoft PowerPoint files, specify *.ppt in the path name.</li></ul> <b>NOTE:</b> You can specify the FullFilePath using the UNC convention.
SourcePath	Location of the linked files on the source computer. Path name can be a local path or UNC path.
TargetPath	Location of the linked files on the target computer. Path name can be a local path or UNC path. <b>NOTE:</b> The link updater verifies that the target folder exists before it updates the links.

Table 27. Optional Parameters

Optional Parameter	Meaning
/r	Search recursively through the folders and subfolders of the paths you have specified.
/t= n	<p>Create a test report that lists the number of files that will be updated. If you specify this option, only the audit report is created. The files are not updated.</p> <p>If you do not specify a number (=n), then the report includes an unlimited number of files to the maximum number allowed.</p> <p><b>NOTE:</b> The maximum number that can be specified using the \t argument is 2147483647.</p>
/c	<p>Use with the /t (test report) option to create a CSV file that lists the files and the links to be updated. This option allows you to review potential changes in a file without updating the links.</p> <p>If you use the /c option without using /t, you get a CSV file that contains all the file links that were updated.</p> <p>The CSV file is created in the same directory in which the link updater utility is running. The file uses the following naming convention: LINK_UPDATER_LINKS_FOUND_ddmmyy_hh_mm.csv</p>
/z	Delete previously generated LINK_UPDATER files, including the .log, .csv, and .htm files.

**i** **NOTE:** Any file or folder names that contain spaces must be enclosed in quotation marks (""). You must enter the source and target paths using a balanced syntax.

### Correct

```
LU *.doc C:\SourceFolder\ D:TargetFolder\
```

### Incorrect

```
LU *.doc C:\SourceFolder\ D:TargetFolder
```

Since the incorrect example has \ after SourceFolder but not after TargetFolder, the Link Updater replaces C:\SourceFolder\ with D:\TargetFolder. So, in effect, the TargetFolder name is incorrect as a prefix to the updated file links. The Link Updater would determine that the target path does not exist and the files are not updated.

### Example for specifying path information

You want to update the links for migrated Microsoft Word files located here: C:\Folder1.

The Word files have links to PowerPoint files that were previously located here: D:\Corporate\DivisionB. The PowerPoint files are now located here: D:\Corporate\HR\PP.

```
LU C:\Folder1\*.doc D:\Corporate\DivisionB D:\Corporate\HR\PP
```

### Identifying all source paths

You can use the test report option to show all source paths. To do this, you enter \\ instead of specifying the source path.

The syntax to produce a test report that shows all source paths is as follows:

```
LU FullFilePath \\ TargetPath /t
```

Since you are running the Link Updater in test mode and no links are updated, you can enter a dummy path as the target path. For example, you could enter \\Test as the target path.

# Using a .ini file from the command line

Use the following syntax to run Link Updater from the command line using an .ini file to specify the paths:

```
LU FullFilePath /F= INIFile [/r] [/t= n] [/c] [/z]
```

INIFile is the full path name for the .ini file that contains the update information about the source computer and the target computer for the linked files.

## Link Updater for Access

Link Updater for Microsoft Access updates external table links to other Microsoft Access databases and Excel spreadsheets, and updates hyperlinks found in Access table records. This utility performs automatic backups of the Access database file.

- i** **IMPORTANT:** Microsoft Office is required for Link Updater for Access. Do not run Microsoft Office applications on the computer on which the Link Updater for Access is running. If you have Excel open when you run Link Updater for Access, Excel will be forcibly closed with no prompting to save your files.
- IMPORTANT:** You must create a link map file to use this utility. See [Creating a link map .ini file](#).

### To update external table links

- 1 Click **Update Utilities**, and click **Link Updater for Access**.
- 2 Open the **Settings** tab.
- 3 Type the path or browse to locate the Microsoft Access files that contain links you want to update.
- 4 Type the path or browse to locate the link map file that maps the old locations of linked files to the new locations.
- 5 Set options for the update.

#### **Test Mode (no updates)**

By default, the Link Update runs in test mode, which allows you to scan the path and see the updates without making changes to the file.

#### **Enable Debug Logging**

Select to see detailed level logging.

- 6 Open the Microsoft Access tab.
- 7 Set options for Microsoft Access.

#### **Enable Microsoft Access Database Updates**

Select to check Microsoft Access files for external table links and hyperlinks.

#### **Update external table links**

Select to check and update external table links. The current link types supported are links to other tables in external Microsoft Access files, and links to external Microsoft Excel spreadsheets.

#### **Update Hyperlink fields in table records**

Select to scan table records for hyperlink fields. This process may take some time if the table has many records.

#### **Back up Access database file before updating**

Select to create a backup copy of the .mdb or .accdb file made to the same location as the existing file. The file will have an extension of .BAK. The backup is made before scanning the Microsoft Access database file for changes. If no changes are made, the backup file is removed.

- 8 Open the **Scan** tab.
- 9 Click **Scan**. The Statistics area updates as the scan progresses.

- i** **NOTE:** If you selected **Test mode** on the Settings tab, no files are updated.

10 To display the log file containing a summary of the actions performed, click **View Log**.

# Registry Updater

You can use the Registry Updater (RegTool.exe) to search and replace registry entries on client computers after a migration. The Registry Updater updates the registry based on an .ini file that contains the specified registry entries that are used to update the client computers.

For example, after a data migration you may need to update drive mappings in user local and roaming profiles. The Registry Updater replaces outdated links with links to the new server, so the computers can identify the new location of the data.

**i** | **NOTE:** Before you run the Registry Updater, you must create an .ini file for the drive mappings.

Topics:

- [Creating the drive mapping .ini file](#)
- [Running the Registry Updater](#)
- [Running Registry Updater from the command line](#)
- [Using the Registry Updater in a logon script](#)

## Creating the drive mapping .ini file

The .ini file is used to change the drive mappings in user local and roaming profiles from an old server mapping to a new server mapping.

A template .ini file is available to use to create your own .ini file. The template file is named drivemap.ini and is located in C:\Program Files\Quest\Secure Copy 7\Tools.

### Format

```
;[Values]
;HKEY_CURRENT_USER\Network = ServerMap,Recurse
;
;[ServerMap]
;SourceServer\OldShare = TargetServer\NewShare
;SourceServer = TargetServer
;OldValue = NewValue
```

The [Values] section identifies the registry keys to search and replace. Drive mappings for a user are stored in the HKEY\_CURRENT\_USER\Network registry key. You can add the optional Recurse to include subkeys and associated values.

**i** | **NOTE:** If recursion is not set, the Registry Updater searches and replaces only values that are directly under the registry key.

The [ServerMap] section defines a mapping of old server to new server. You can map a server to a share on another server and you can map a share on a server to a new share on a server.

**i** | **IMPORTANT:** Only one mapping rule is applied and the rules are processed in order. This allows you to map old shares to new shares with different names.

### Example

You migrated data from server FS\_NT to server FS\_2K. Several shares were migrated and you renamed some of the shares because of conflicts on the target server or because of new naming conventions. You migrated shares named Software, Public, Accts, and Sales. During the migration, you renamed Accts to Accounts and Sales to UKSales. The .ini file to update those users that still have drive mappings to the old server and old shares might look as follows:

```

;Example
;[Values]
;HKEY_CURRENT_USER\Network = ServerMap,Recurse

;[ServerMap]
;FS_NT\Sales = FS_2K\UKSales
;FS_NT\Accts = FS_2K\Accounts
;FS_NT = FS_2K

```

## Running the Registry Updater

- 1 Click **Update Utilities**, and click **Registry Updater**.
- 2 Type the path or browse to locate the .ini file that you created.
- 3 Type the name of the computer where the Registry Updater will update the registry.
- 4 You can run the Registry Updater through the Registry Tool dialog box or you can run it from the Command Line.
  - Click to **Run** the specified .ini file with the specified arguments.
  - Click **Launch cmd.exe** to run the Registry Updater from the command line.

## Running Registry Updater from the command line

The Registry Updater (ToolsRegTool.exe) is located in: C:\Program Files\Quest\Secure Copy 7\Tools.

### Format

```
RegTool /i=INIFile [/c=ComputerName] [/a=AuditFile]
```

INIFile is the name and path of the .ini file that you created.

ComputerName is the computer where the Registry Updater will update the registry. If you do not specify this argument, the update is run on the local computer.

AuditFile is the path to the file that saves the information about the registry keys that were updated and those that could not be updated. (Optional)

### Examples

```
RegTool /i=C:\RegTool\updates.ini /c=USERCOMP01 /a=C:\RegTool\audit.log
```

```
RegTool /i=\\FILSRV1\RegToolShare\updates.ini /c=USERCOMP01 /a=C:\RegTool\audit.log
```

## Using the Registry Updater in a logon script

The Registry Updater is typically distributed through logon scripts that run when users first log on to their computers after the migration. When you create the logon script, be aware of the following two points:

- The logon script should only run once.
- After the script has run, the user must log off and then log on for the changes to take effect.

# Troubleshooting

Secure Copy has several tools that you can use to help troubleshoot your copy jobs. Quest Technical Support is also available to help you. You can access the Quest Support Portal at <https://support.quest.com>.

Topics:

- [Logging events for Technical Support](#)
- [Removing Secure Copy](#)

## Logging events for Technical Support

You can collect information while you run a copy job to help our Technical Support staff troubleshoot any problems you may be having. Use the Event Logging utility to capture a log file and then submit it to Technical Support.

### *To log events for Technical Support*

- 1 Select **Tools | Advanced Support Tool**.
- 2 Select **Enable Support Logging**.
- 3 Choose the type of errors to capture.
- 4 Type the path to where the log file will be saved, or click **Browse** to locate a path.
- 5 Your license number is automatically filled in, but you need to add your contact name, email, and phone number.
- 6 Open the **Options** tab.
- 7 Select the options as directed by your support representative. Include the Case ID if you have one.
- 8 Click **OK**.
- 9 Run your copy job to collect the errors.
- 10 Select **Tools | Advanced Support Tool**.
- 11 Click **Save Logs**.
- 12 To open a support case, click Quest Technical Support.

## Removing Secure Copy

### *To remove Secure Copy*

- 1 From the Windows® Control Panel, double-click **Add/Remove Programs**.
- 2 From the list of currently installed programs, select **Secure Copy 7**.

- 3 Click **Remove**. A message box prompts you for confirmation.
- 4 To remove the application, click **Yes**.

After removal is complete, Secure Copy will have been removed from your system. Note that the installation directory that contained Secure Copy remains after the process is complete. This directory contains the license file for the product and any files created after the product was installed. These may be deleted manually if you wish to completely remove Secure Copy.

# PowerShell cmdlets

Microsoft® Windows PowerShell® is a Windows® command-line shell and scripting language designed specifically for system administrators and built on top of the Microsoft .NET Framework. Secure Copy® supports the use of PowerShell cmdlets.

Topics:

- [What are cmdlets?](#)
- [Using the PowerShell cmdlets](#)
- [Managing copy jobs](#)
- [Running the File System Statistics Analyzer](#)

## What are cmdlets?

Windows PowerShell® has the concept of cmdlets. A cmdlet is a simple, single-function command that manipulates objects and is designed to be used in combination with other cmdlets.

If you already had Windows PowerShell installed on your computer before you installed Secure Copy®, the Secure Copy cmdlets were automatically installed and registered with Windows PowerShell.

The examples in this section show you leverage the cmdlets available in Secure Copy. These cmdlets allow you to perform some of the functions of Secure Copy in an automation environment. The cmdlets also can be of great use in any environment where a repetitive process involving Secure Copy is needed.

The complete set of Secure Copy PowerShell cmdlets is as follows.

**Table 28. Secure Copy cmdlets for use with Windows PowerShell**

Cmdlet	Module	Reference
Start-SecureCopyJob	SCYPowerShellCore	<a href="#">Starting a copy job</a>
Remove-SecureCopyJob	SCYPowerShellCore	<a href="#">Removing a copy job</a>
Start-FileSystemStatistics	FileSystemStatisticsPowerShell	<a href="#">Running the File System Statistics Analyzer</a>



**NOTE:** All cmdlets should be run while logged on as an Administrator. The Secure Copy cmdlets should be used only by those familiar with Windows PowerShell.

# Using the PowerShell cmdlets

You can run Secure Copy from the PowerShell cmdlets in the SCYPowerShellCore PowerShell module. You can run the File System Statistics Analyzer from the PowerShell cmdlets in the FileSystemStatisticsPowerShell PowerShell module.

To use the Secure Copy PowerShell cmdlets, you need to import the modules, which are located in the Secure Copy 7 installation folder.

## To import the PowerShell modules, run the following:

```
Import-Module "C:\Program Files\Quest\Secure Copy 7\SCYPowerShellCore.dll"
```

```
Import-Module "C:\Program Files\Quest\Secure Copy 7\Analyzer\FileSystemStatisticsPowerShell.dll"
```

# Managing copy jobs

Similar to the SecureCopyCmd.exe runs from the command line, the SCYPowerShellCore PowerShell module offers only limited options to script, because it references the features of a saved job by using the name of that job.

**i** **NOTE:** You must use SCYPowerShellCore PowerShell module from a computer that has a fully licensed version of Secure Copy 7 installed. You cannot copy the SCYPowerShellCore PowerShell module from computer to computer.

The SCYPowerShellCore PowerShell module contains two cmdlets:

- [Start-SecureCopyJob](#)
- [Remove-SecureCopyJob](#)

# Starting a copy job

## Syntax

```
Start-SecureCopyJob [-Database] <string> [-JobName] <string> [[-Source] <string>] [[-Target] <string>] [[-CopySubFolders] <bool>] [[-Quiet] <bool>] [[-Test] <bool>] [<CommonParameters>]
```

Parameter	Description
-Database <string>	Specify the jobs database (.ssd file).
-JobName <string>	Specify the job using Job Name.
-Source <string>	Define a new source path. <b>IMPORTANT:</b> If you add /source to the command, it overrides the source(s) specified in the copy job identified by the job ID or name.
-Target <string>	Define a new target path. <b>IMPORTANT:</b> If you add /target to the command, it overrides the target(s) specified in the copy job identified by the job ID or name.
-CopySubFolders <bool>	Specify true or false.
-Test <bool>	Test the job.
-Quiet <bool>	Run the job without the user interface.

## Examples

This example tests the Default job.

```
Start-SecureCopyJob -Database "C:\Program Files\Quest\Secure Copy 7\SecureCopy.ssd"
-JobName Default -Test $true
```

This example runs the Default copy job, overriding the source/target with the specified source/target, which copies My Documents to a backup folder.

```
Start-SecureCopyJob -Database "C:\Program Files\Quest\Secure Copy 7\SecureCopy.ssd"
-JobName Default -Source "c:/CBrown/My Documents" -Target "c:/Backup/My Documents"
```

# Removing a copy job

## Syntax

```
Remove-SecureCopyJob [-Database] <string> [-JobName] <string> [<CommonParameters>]
```

Parameter	Description
-Database <string>	Specify the jobs database (.ssd file).
-JobName <string>	Specify the job using Job Name.

## Example

This example removes the TestJob copy job.

```
Remove-SecureCopyJob -Database "C:\Program Files\Quest\Secure Copy
7\SecureCopy.ssd" -JobName TestJob
```

# Running the File System Statistics Analyzer

You can run the File System Statistics Analyzer from the PowerShell cmdlets by using the FileSystemStatisticsPowerShell PowerShell module, which is located in the Secure Copy 7 installation folder.

## Syntax

```
Start-FileSystemStatistics [[-Roots] <string>] [[-Server] <string>] [-Out] <string>
[[-Threads] <int>] [[-NoBackup] <bool>] [[-Security] <bool>] [[-NoStatus] <bool>]
[<CommonParameters>]
```

**i** | **NOTE:** Either the `-roots <string>` or `-server <string>` parameter is required

Parameter	Description
-roots <string>	List of paths to scan. Separate each path with a semi-colon. <b>NOTE:</b> This parameter must be specified. If there are any spaces in the paths, the entire list should be in quotes.
-server <string>	Name of the server to process. When specified, all normal <non administrator, non IPC> shares are enumerated and used as roots.

Parameter	Description
-out <string>	File in which to write the output. The data written to this file is in comma separated (csv) format and is suitable for import into Microsoft® Excel.
-threads <int>	Number of threads to use to perform the enumeration. The number of threads must be less than or equal to the number of roots specified to ensure that each thread has roots to process. If not specified, one thread is used.
-nobackup <bool>	Avoid the use of the backup rights. If this flag is not specified, the backup right is enabled. <b>NOTE:</b> Backup rights must be held on both the server where this application is run, and the target server.
-security <bool>	Instruct the application to capture security information in addition to count and size information.
-NoStatus <bool>	Suppress the command window and run the tool in quiet mode.

## Examples

This example retrieves information for all shares.

```
Start-FileSystemStatistics -server SERVERNAME -out ServerName-outputfile.csv
```

This example retrieves information for a set of shares.

```
Start-FileSystemStatistics -roots "\\SERVERNAME\Share1;\\SERVERNAME\Share Number 2"
-out ServerName-outputfile.csv
```

Quest provides software solutions for the rapidly-changing world of enterprise IT. We help simplify the challenges caused by data explosion, cloud expansion, hybrid datacenters, security threats, and regulatory requirements. We are a global provider to 130,000 companies across 100 countries, including 95% of the Fortune 500 and 90% of the Global 1000. Since 1987, we have built a portfolio of solutions that now includes database management, data protection, identity and access management, Microsoft platform management, and unified endpoint management. With Quest, organizations spend less time on IT administration and more time on business innovation. For more information, visit [www.quest.com](http://www.quest.com).

## Technical support resources

Technical support is available to Quest customers with a valid maintenance contract and customers who have trial versions. You can access the Quest Support Portal at <https://support.quest.com>.

The Support Portal provides self-help tools you can use to solve problems quickly and independently, 24 hours a day, 365 days a year. The Support Portal enables you to:

- Submit and manage a Service Request
- View Knowledge Base articles
- Sign up for product notifications
- Download software and technical documentation
- View how-to-videos
- Engage in community discussions
- Chat with support engineers online
- View services to assist you with your product.